

Contents

Model

- 50DLU6.75S
- 50DLU6.75
- 50DLU61.5S
- 50DLU61.5
- 80DLMU61.5S
- 80DLMU61.5
- 80DLU62.2S
- 80DLMU62.2S
- 80DLU63.7S
- 80DLMU63.7S
- 100DLU61.5S
- 100DLU61.5
- 100DLU62.2S
- 100DLU63.7S
- 100DLMU63.7S

Section	Page
Specifications	2-103
Selection Chart	2-106
Performance Curves	2-107
Outline Drawings	2-113
Sectional View	2-119
QDC Information	2-278
Technical Information	2-289.1
material specification	
impeller description	
motor protection	
cable entry	
paint specifications	
mechanical seal	
general	
Motor Data	2-315.1
motor electrical specifications	
cable data	
wiring diagrams	
motor electrical data	



Model Designation

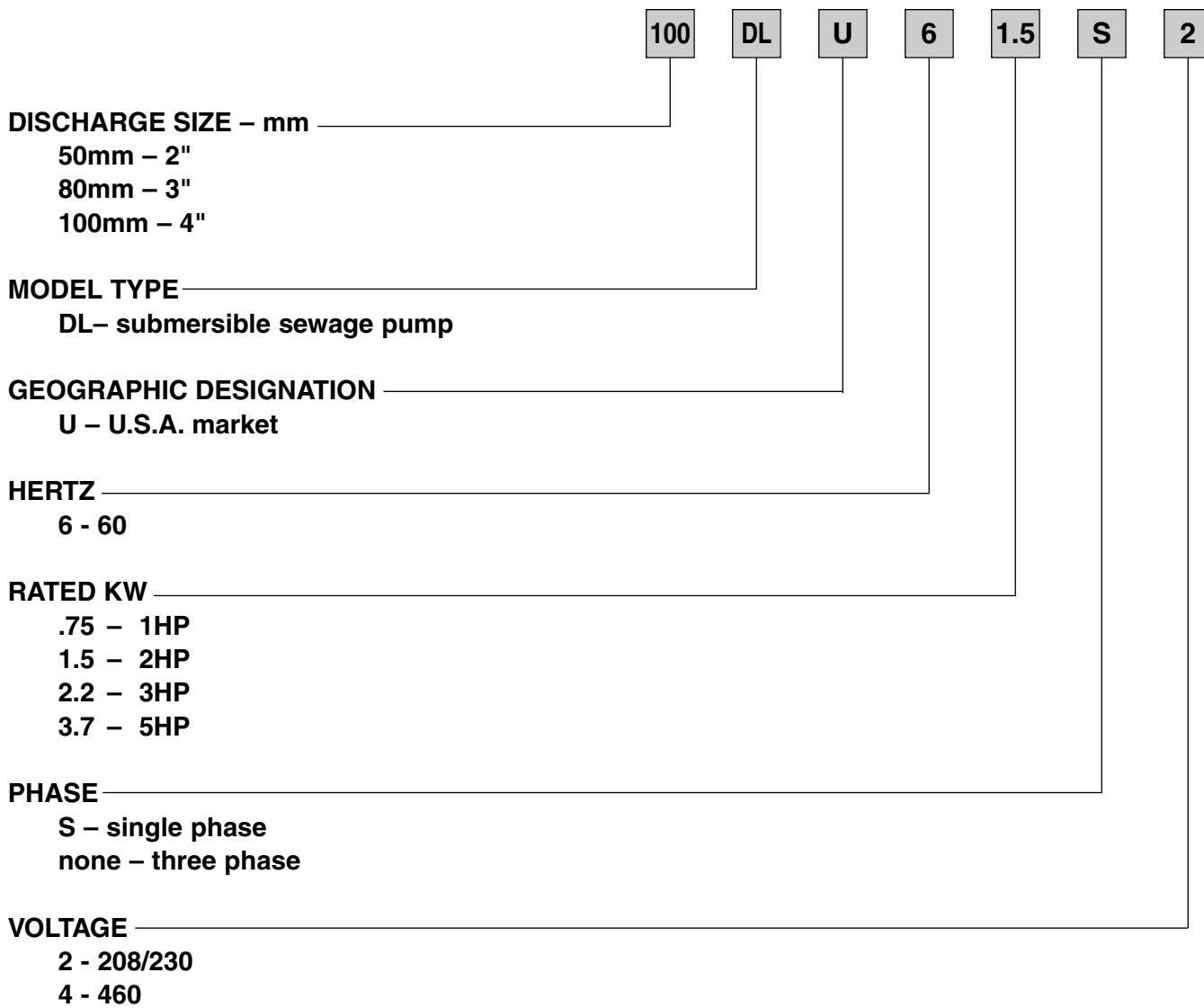

Specifications

Model DLU
Specifications

	Standard	Optional
Size	2, 3, 4 inch	
Range of HP	1 to 2 HP Three Phase 1 to 5 HP Single Phase	
Range of Performance	Capacity 13 to 430 GPM Head 9 to 66 feet	
Limitation Maximum Water Temperature	104°F (40°C)	
Synchronous Speed	1800 RPM	
Materials Casing Impeller Shaft Motor Frame Fastener	Cast Iron Cast Iron 403 Stainless Steel Cast Iron 304 Stainless Steel	
Mechanical Seal Material – Upper Side Material – Lower Side Impeller Type Bearing Motor Single Phase Three Phase Service Factor Motor Protection Single Phase Three Phase Accessories	Double Mechanical Seal Carbon/Ceramic Silicon Carbide/Silicon Carbide Semi-open Prelubricated Ball Bearing Air-filled, Insulation Class F 208/230V 208/230/460V 1.15 Built-in Auto Cut - overload, out of phase, single phasing protection Submersible cable 33 ft.	66 ft. QDC System

Specifications

A. General:

Provide submersible sewage pumps suitable for continuous duty operation underwater without loss of watertight integrity to a depth of 65 feet. If mounted on a guide rail system, design shall be such that the pump will be automatically connected to the discharge piping when lowered into place on the discharge connection. The pump shall be easily removable for inspection or service, requiring no bolts, nuts, or other fasteners to be disconnected, or the need for personnel to enter the wet well. The motor and pump shall be designed, manufactured, and assembled by the same manufacturer.

B. Manufacturer:

EBARA International Corporation

C. Pump Characteristics:

Pumps shall conform to the following requirements:

Number of units	
Design flow (gpm)	
Design TDH (ft)	
Minimum shut off head (ft)	
RPM	1800
Maximum HP	
Minimum efficiency at design (%)	
Minimum power factor at design (%)	
Voltage/HZ	208/230V, 460V / 60
Phase	

D. Pump Construction:

All major parts of the pumping unit(s) including casing, impeller, suction cover, motor frame and discharge elbow shall be manufactured from gray cast iron, ASTM A-48 Class 30. Castings shall have smooth surfaces devoid of blow holes or other casting irregularities. Casing design shall be centerline discharge with a large radius on the cut water to prevent clogging. Units shall be furnished with a discharge elbow and 125 lb. flat face ANSI flange. All exposed bolts and nuts shall be 304 stainless steel. All mating surfaces of major components shall be machined and fitted with NBR O-rings where watertight sealing is required. Machining and fitting shall be such that sealing is accomplished by automatic compression of O-rings in two planes and O-ring contact is made on four surfaces without the requirement of specific torque limits. Internal and external surfaces are prepared to SPPC-VISI-SP-3-63 then coated with a zinc-chromate primer. The external surfaces are then coated with a H.B. Tnemecol 46-465 Coal Tar paint.

Impeller shall be single vane semi-open design for 1-2 HP units, single or multi-vane semi-open design for 3 HP units, and multi-vane semi-open design for 5 HP units. The impeller design shall include back pump out vanes to reduce the pressure and entry of foreign materials into the mechanical seal area. The inlet edge of the impeller vanes shall be angled toward the impeller periphery so as to facilitate the release of objects that might otherwise clog the pump. Impellers shall be direct connected to the motor shaft with a slip fit, key driven, and secured with an impeller bolt. The unit shall include a replaceable suction cover that is designed such that it may be adjusted to maintain working clearances and hydraulic efficiencies.

Double mechanical seals operating in an oil bath shall be provided on all units. The oil filled seal chamber shall be designed to prevent over-filling and include an anti-vortexing vane to insure proper lubrication of both seal faces. Lower face materials shall be silicon carbide vs. silicon carbide, upper faces carbon vs. ceramic, NBR elastomers, and 304SS hardware. Seal system shall not rely on pumping medium for lubrication.

Specifications

E. Motor Construction:

The pump motor shall be an air filled induction type with a squirrel cage rotor, shell type design, built to NEMA MG-1, Design B specifications. Stator windings shall be copper, insulated with moisture resistant Class F insulation, rated for 311°F. The stator shall be dipped and baked three times in Class F varnish and heat shrunk fitted into the stator housing. Rotor bars and short circuit rings shall be manufactured of cast aluminum. Motor shaft shall be one piece AISI403 material, rotating on two permanently lubricated ball bearings designed for a minimum B-10 life of 60,000 hours. Motor service factor shall be 1.15 and capable of up to 20 starts per hour. The motor shall be designed for continuous duty pumping at a maximum sump temperature of 104°F. Voltage and frequency tolerances shall be a maximum 10 / 5% respectively. Junction area shall include a terminal board for power connections on all three (3) phase units. Motor protection shall be provided by an auto-cut device located directly over the windings to provide protection from single phasing, low voltage, phase imbalance, locked rotor, and no load or run dry conditions. Motor shall be non-overloading over the entire performance curve and be able to operate at full load intermittently while unsubmerged without damage to the unit.

Power cable jacket shall be manufactured of an oil resistant chloroprene rubber material, designed for submerged applications. Cable shall be watertight to a depth of a least 65'. Cable entry shall be composed of a one piece, vulcanized, three way mechanical sealing system with a thick molded shoulder with increasing cable diameters to resist fatigue from bending forces. The molded shoulder, acts as the primary and secondary sealing points. This system shall also prevent leakage into the motor housing due to capillary action through the insulation if the cable is damaged or cut. A metallic plate shall be utilized to clamp the entry system to the motor housing. Strain relief shall be accomplished by clamping and attaching the cable with chain to the motor housing.

F. Guide Rail system:

Design shall include two (2) 304SS schedule 40 guide rails sized to mount directly to the quick discharge connector, QDC, at the floor of the wet well and to a guide rail bracket at the top of the wetwell below the hatch opening, (refer to project drawings). Intermediate guide brackets are recommended for rail lengths over 15 feet.

Guide rails are not part of the pump package and shall be supplied by others.

The QDC shall be manufactured of cast iron, ASTM A48 Class 30. It shall be designed to adequately support the guide rails, discharge piping, and pumping unit under both static and dynamic loading conditions with support legs that are suitable for anchoring it to the wetwell floor. The face of the inlet QDC flange shall be perpendicular to the floor of the wetwell. The discharge flange of the QDC shall conform to ANSI B16.1 Class 125.

The pump design shall include an integral self-aligning sliding bracket. Sealing of the pumping unit to the QDC shall be accomplished by a single, linear, downward motion of the pump. The entire weight of the pump unit shall be guided to and wedged tightly against the inlet flange of the QDC, making metal to metal contact with the pump discharge forming a seal without the use of bolts, gaskets or O-rings.

Lifting chain shall be galvanized (stainless steel) suitable for removing and installing the pump unit.

Selection Chart

Model DLU
Selection chart

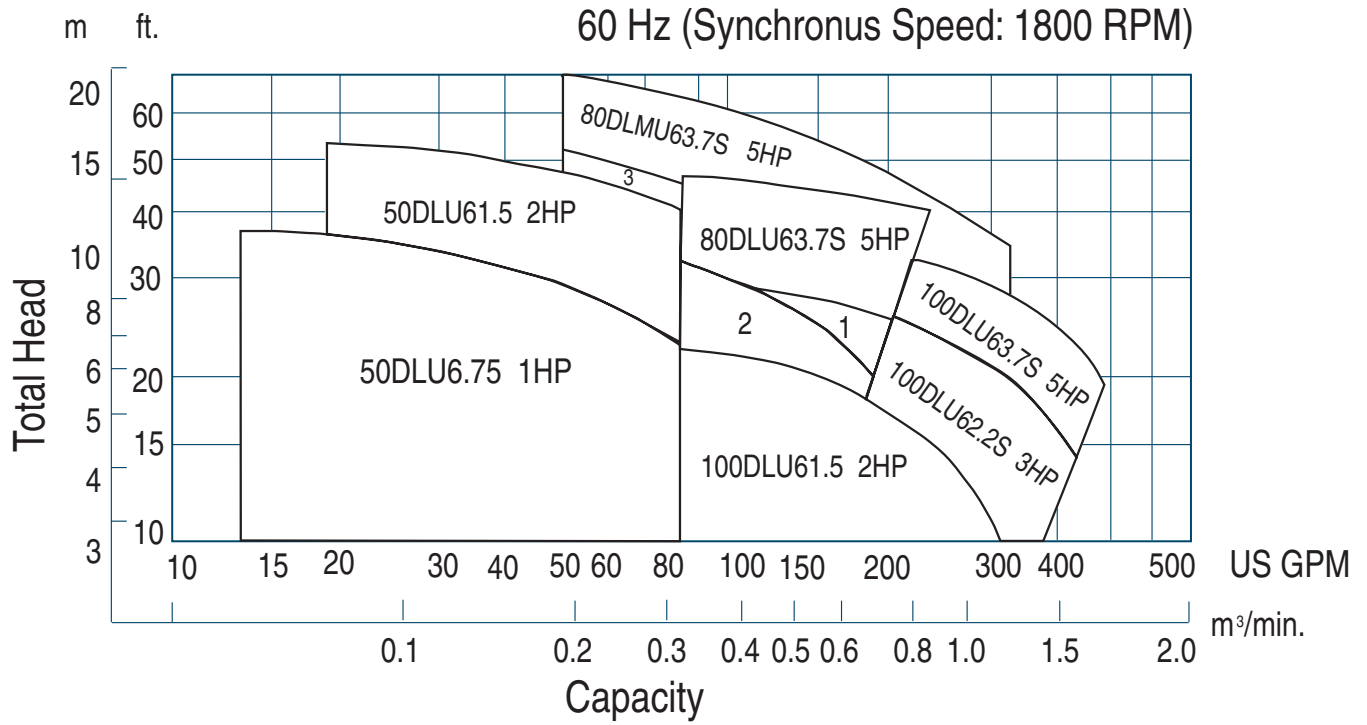

Performance Curves

Project: _____ GPM: _____ TDH: _____ EFF: _____ HP: _____ Chk'd: _____ Date: _____

50DL6.75S 50DL6.75 (1HP) Synchronous Speed: 1800 RPM

2 inch Discharge

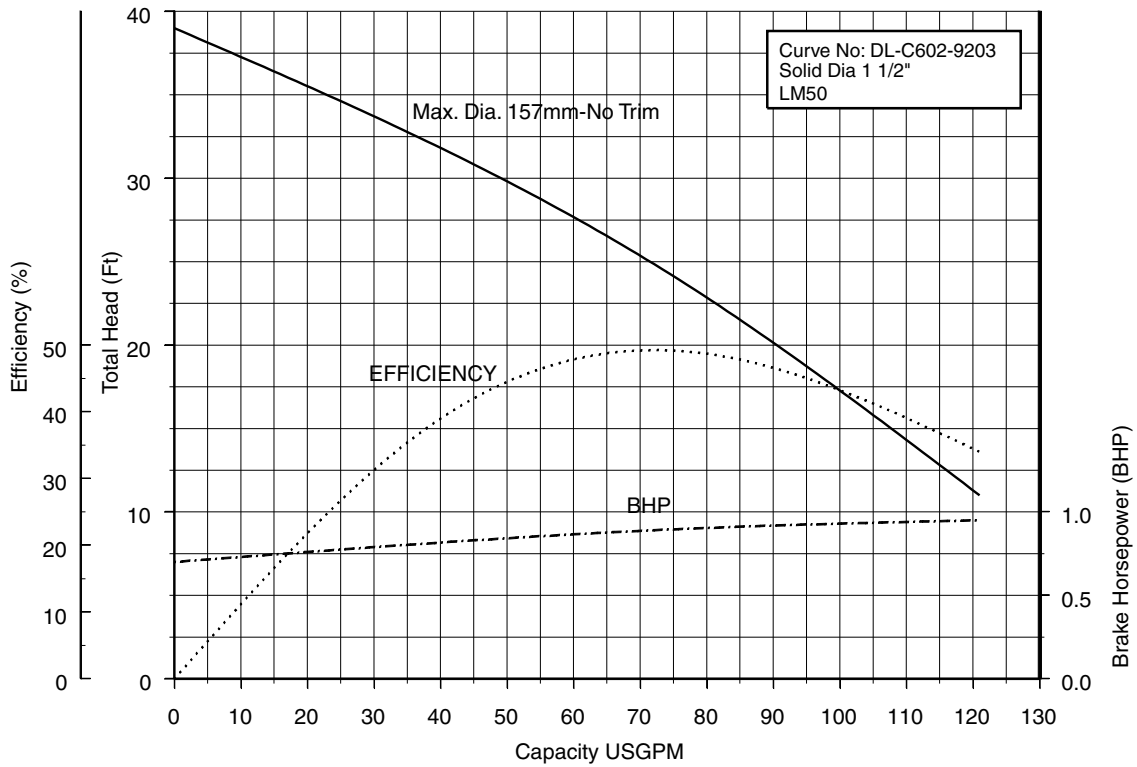

50DL61.5S 50DL61.5 (2HP) Synchronous Speed: 1800 RPM

2 inch Discharge

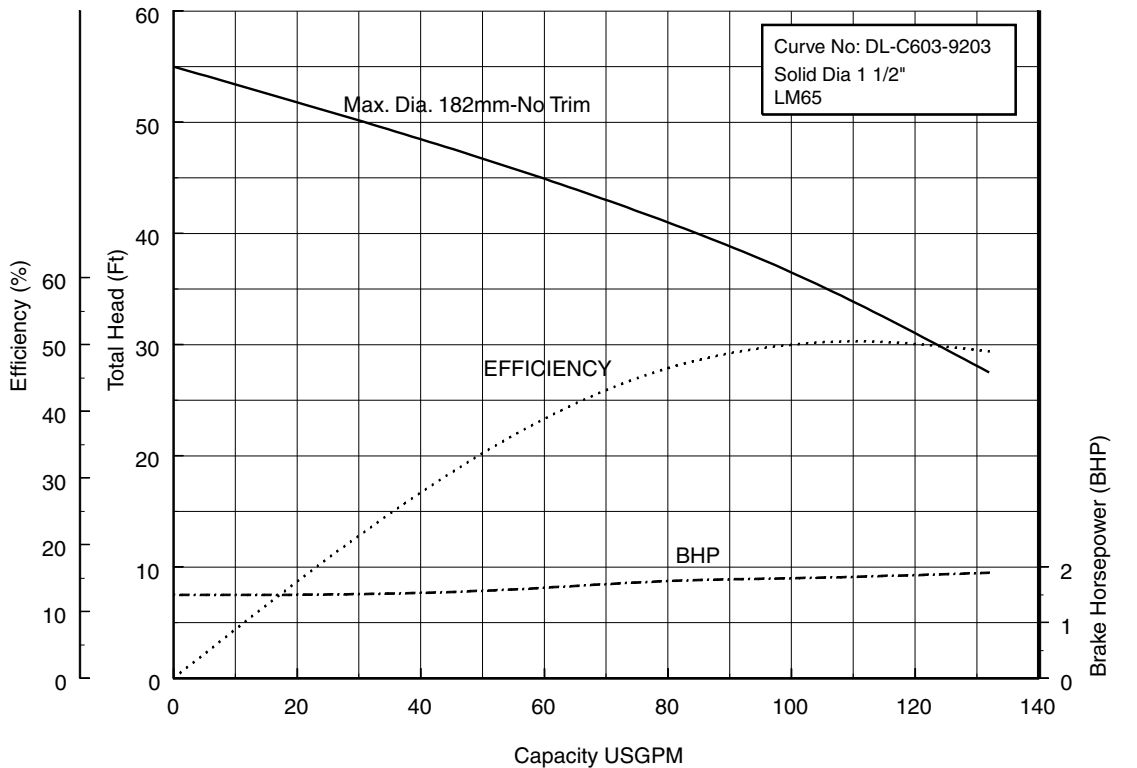

Performance Curves

Project: _____ GPM: _____ TDH: _____ EFF: _____ HP: _____ Chk'd: _____ Date: _____

80DLM61.5S 80DLM61.5 (2HP) Synchronous Speed: 1800 RPM 3 inch Discharge

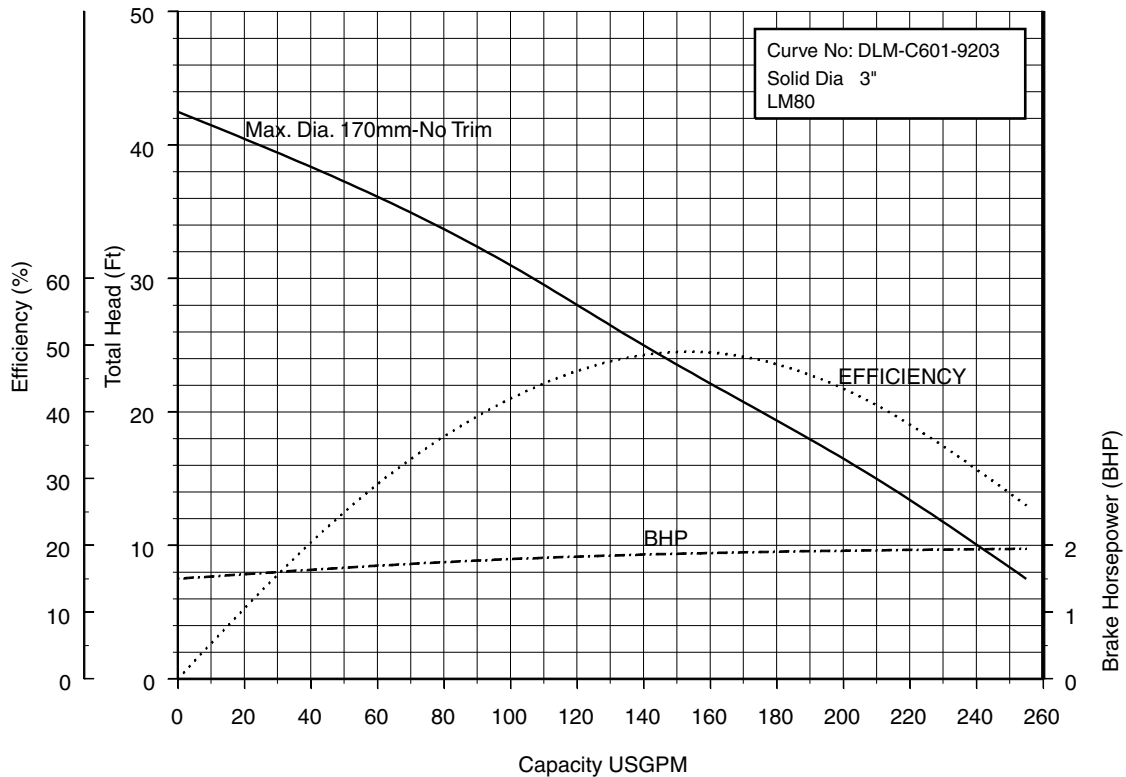

80DL62.2S (3HP) Synchronous Speed: 1800 RPM 3 inch Discharge

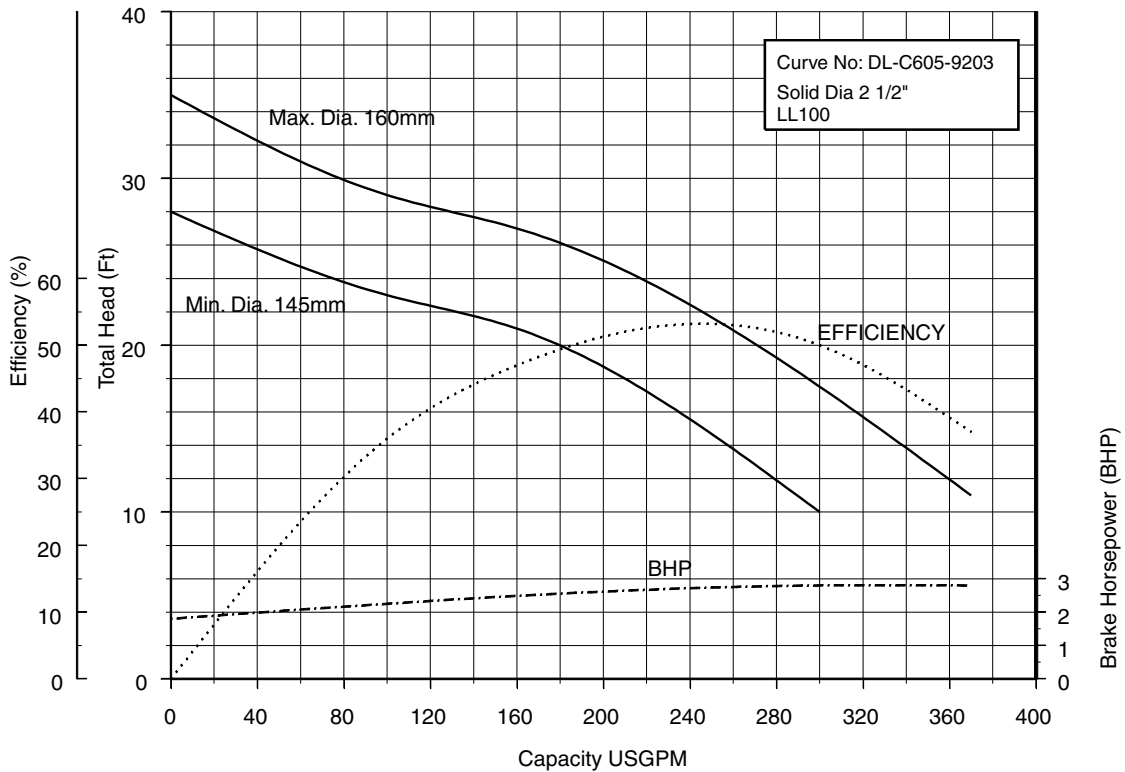

Performance Curves

Project: _____ GPM: _____ TDH: _____ EFF: _____ HP: _____ Chk'd: _____ Date: _____

80DLM62.2S (3HP) Synchronous Speed: 1800 RPM

3 inch Discharge

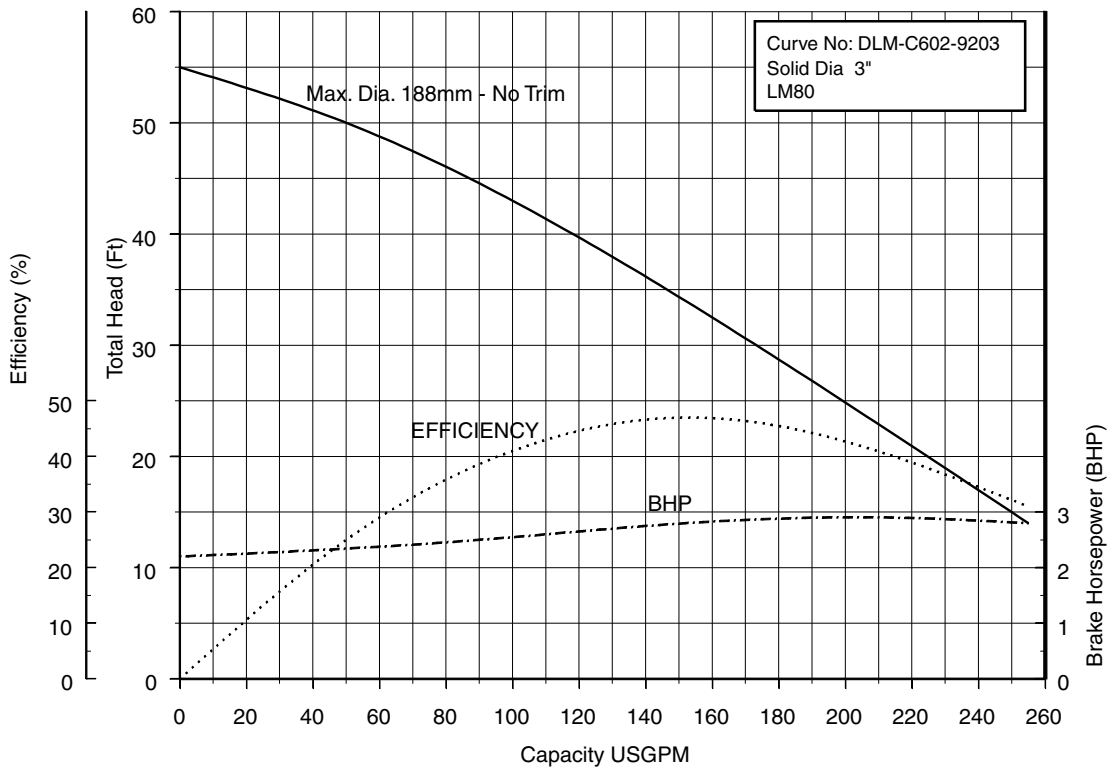

80DL63.7S (5HP) Synchronous Speed: 1800 RPM

3 inch Discharge

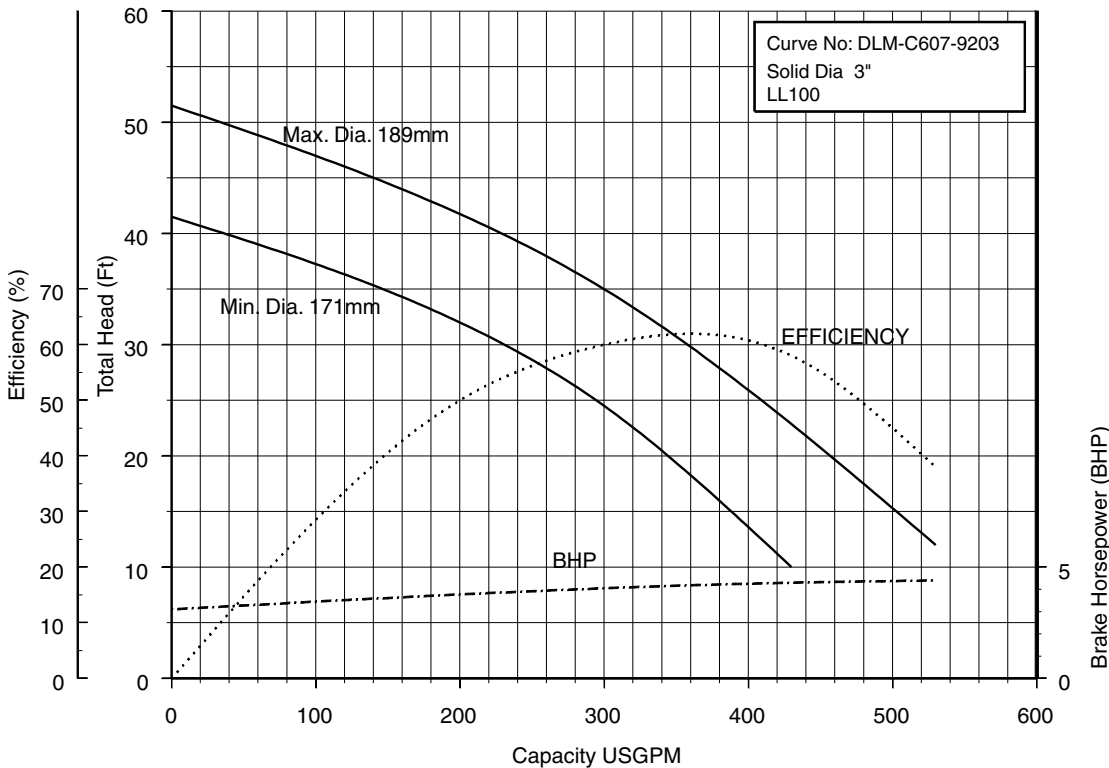

Performance Curves

Project: _____ GPM: _____ TDH: _____ EFF: _____ HP: _____ Chk'd: _____ Date: _____

80DLM63.7S (5HP) Synchronous Speed: 1800 RPM

3 inch Discharge

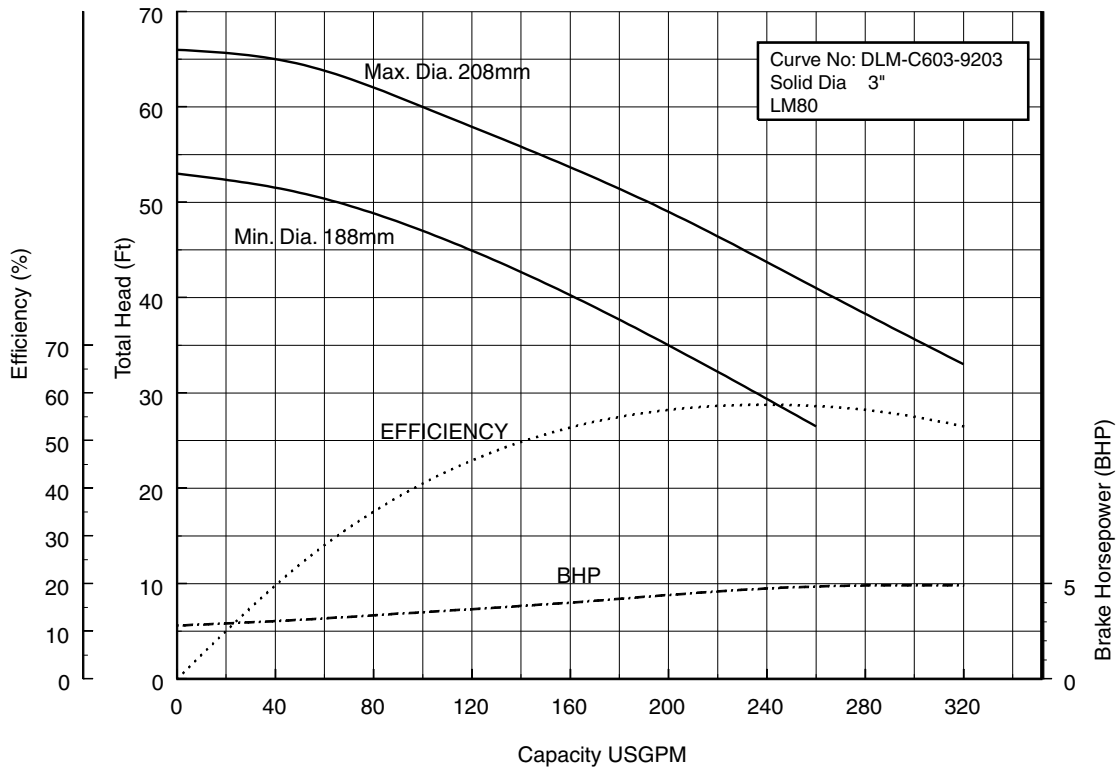

100DL61.5S 100DL61.5 (2HP) Synchronous Speed: 1800 RPM

4 inch Discharge

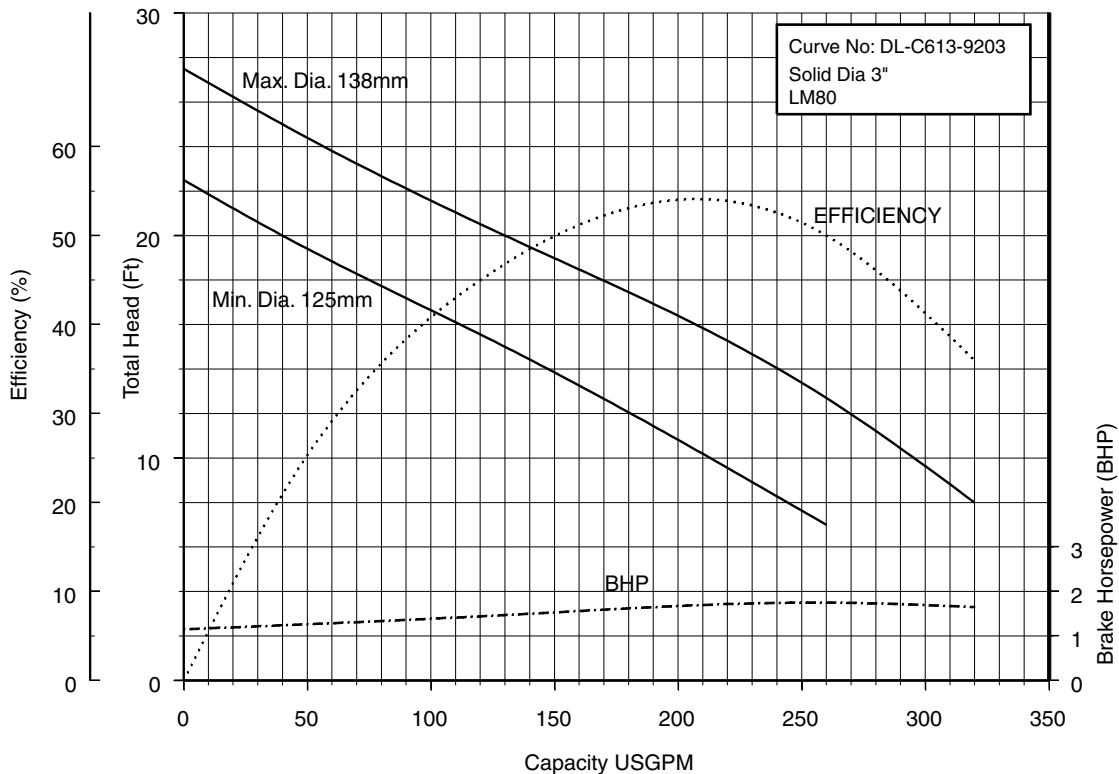

Performance Curves

Project: _____ GPM: _____ TDH: _____ EFF: _____ HP: _____ Chk'd: _____ Date: _____

100DL62.2S (3HP) Synchronous Speed: 1800 RPM

4 inch Discharge

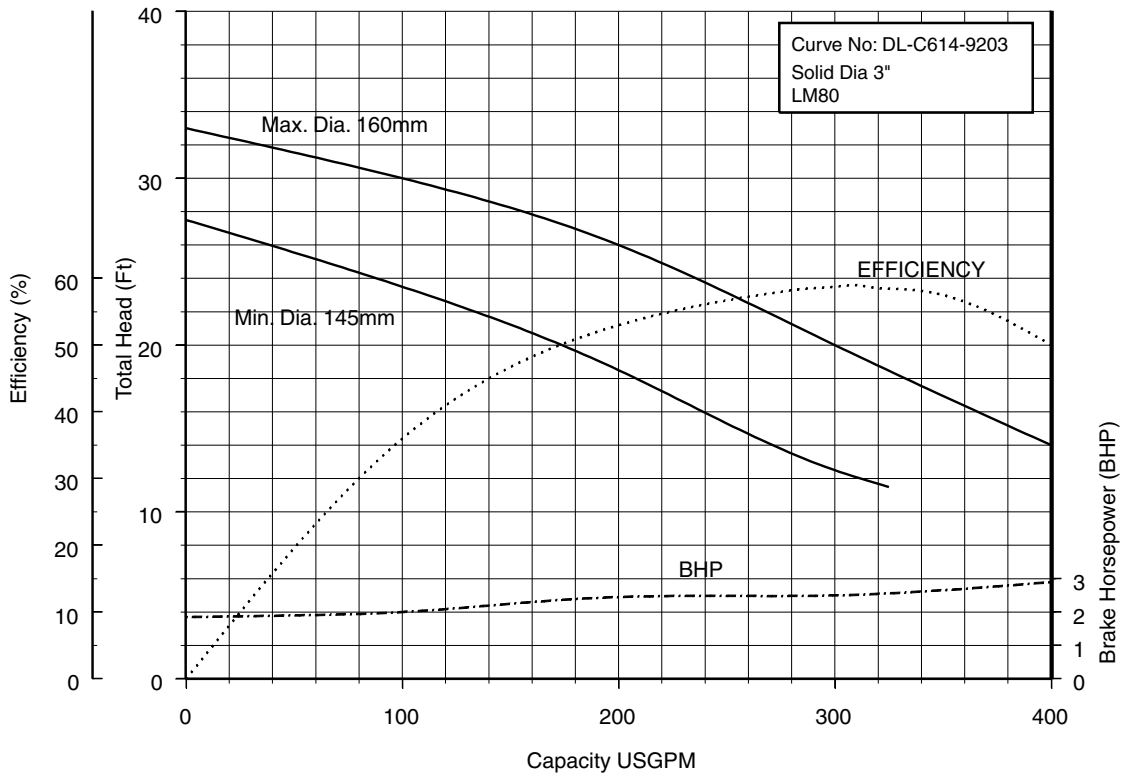

100DL63.7S (5HP) Synchronous Speed: 1800 RPM

4 inch Discharge

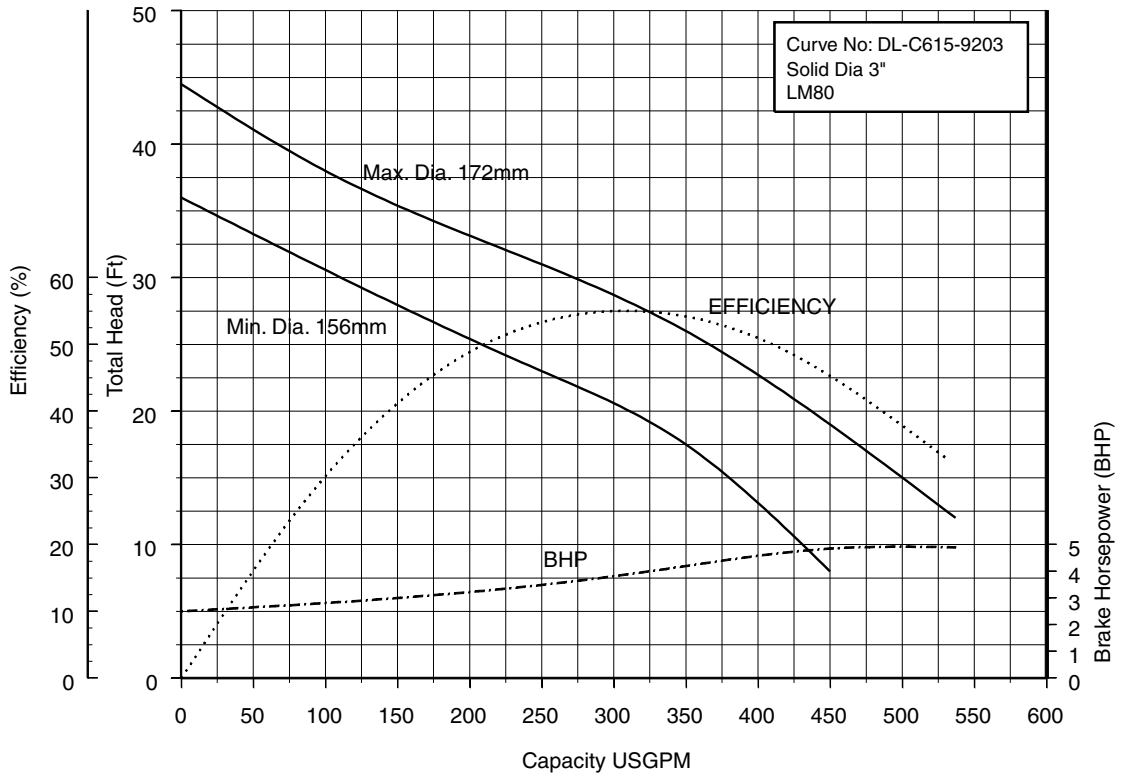

Performance Curves

Project: _____ GPM: _____ TDH: _____ EFF: _____ HP: _____ Chk'd: _____ Date: _____

100DLM63.7S (5HP) Synchronous Speed: 1800 RPM

4 inch Discharge

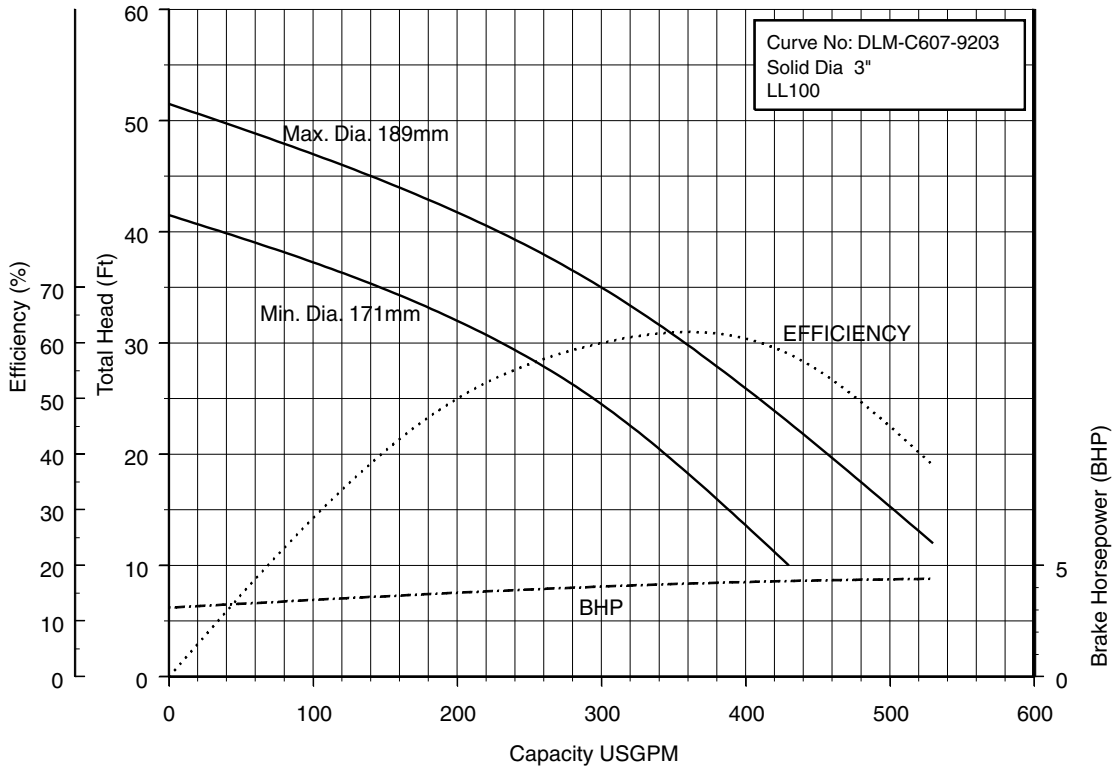

Dimensions

Project: _____ Model: _____ Chk'd: _____ Date: _____

Model DLU, Single and Three Phase

50DLU, 1 to 2HP
 80DLU, 2 to 5 HP
 100DLU, 2 to 5HP

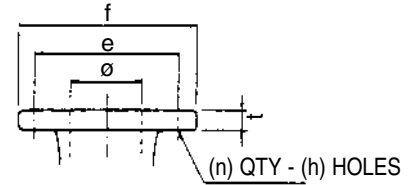
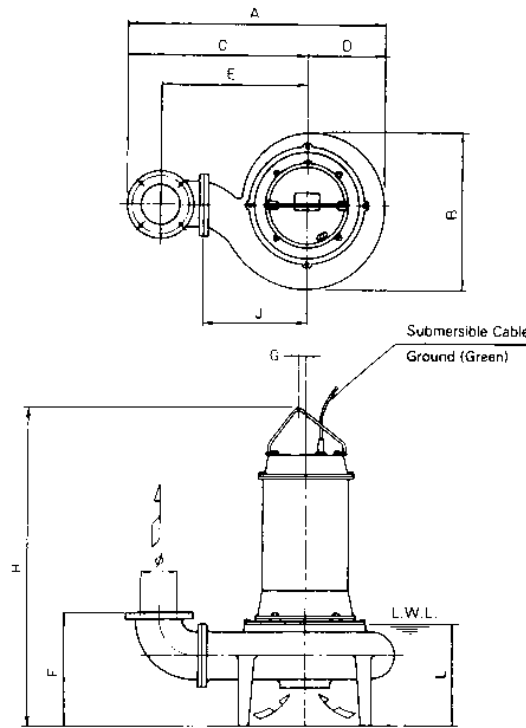

Flange (ANSI 125 PSI F.F)
inch

ø	e	f	t	n	h
2	4 ³ / ₄	6	5 ⁵ / ₈	4	3 ³ / ₄
3	6	7 ¹ / ₂	3 ³ / ₄	4	3 ³ / ₄
4	7 ¹ / ₂	9	15 ¹⁵ / ₁₆	8	3 ³ / ₄

mm

ø	e	f	t	n	h
50	121	152	16	4	19
80	152	191	19	4	19
100	191	229	24	8	19

Dimensions: inch

PHASE	SIZE ø	MODEL	OUTPUT		PUMP & MOTOR										WEIGHT Lb
			kW	HP	A	B	C	D	E	F	G	H	J	L	
SINGLE	2	50DLU6.75S	0.75	1	15 ¹ / ₂	8 ³ / ₄	11 ¹ / ₈	4 ⁵ / ₁₆	8 ⁷ / ₈	6 ⁷ / ₈	1	21 ⁵ / ₁₆	5 ⁷ / ₈	5 ¹ / ₂	77
		50DLU61.5S	1.5	2	18 ³ / ₁₆	10 ³ / ₁₆	12 ⁵ / ₈	5 ¹ / ₁₆	9 ⁵ / ₈	7 ⁷ / ₈	13 ¹³ / ₁₆	22 ¹¹ / ₁₆	7 ¹ / ₁₆	6 ⁵ / ₁₆	97
	3	80DLU61.5S	1.5	2	20 ⁷ / ₁₆	11 ¹ / ₂	15	5 ³ / ₄	11 ¹ / ₄	8 ¹¹ / ₁₆	13 ¹³ / ₁₆	23 ³ / ₂	8 ¹ / ₄	7 ¹ / ₈	112
		80DLU62.2S	2.2	3	23 ¹³ / ₁₆	13 ³ / ₁₆	17 ⁹ / ₁₆	6 ⁵ / ₈	13 ³ / ₈	9 ¹³ / ₁₆	13 ¹³ / ₁₆	28 ³ / ₈	9 ¹ / ₄	8 ¹ / ₈	170
	4	80DLU63.7S	3.7	5	23 ¹³ / ₁₆	13 ³ / ₁₆	17 ⁹ / ₁₆	6 ⁵ / ₈	13 ³ / ₈	9 ¹³ / ₁₆	13 ¹³ / ₁₆	30 ³ / ₁₆	9 ¹ / ₄	8 ¹ / ₈	176
		100DLU61.5S	1.5	2	21 ¹³ / ₁₆	10 ¹ / ₂	16 ⁹ / ₁₆	5 ¹ / ₄	12	10 ¹³ / ₁₆	13 ¹³ / ₁₆	24 ¹⁵ / ₁₆	7 ⁷ / ₈	8 ⁹ / ₁₆	134
		100DLU62.2S	2.2	3	22 ⁷ / ₈	11 ¹ / ₈	17 ⁹ / ₁₆	5 ⁹ / ₁₆	12 ¹³ / ₁₆	10 ¹³ / ₁₆	1	28 ¹⁵ / ₁₆	8 ¹¹ / ₁₆	8 ¹¹ / ₁₆	159
		100DLU63.7S	3.7	5	22 ⁷ / ₈	11 ¹ / ₈	17 ⁹ / ₁₆	5 ⁹ / ₁₆	12 ¹³ / ₁₆	10 ¹³ / ₁₆	1	30 ³ / ₄	8 ¹¹ / ₁₆	8 ¹¹ / ₁₆	183
THREE	2	100DLMU63.7S	3.7	5	24 ⁹ / ₁₆	13 ³ / ₁₆	17 ¹⁵ / ₁₆	6 ⁵ / ₈	13 ³ / ₈	9 ¹³ / ₁₆	5 ⁵ / ₁₆	31 ¹³ / ₁₆	9 ¹ / ₄	8 ¹ / ₁₆	209
		50DLU6.75	0.75	1	15 ¹ / ₂	8 ³ / ₄	11 ¹ / ₈	4 ⁵ / ₁₆	8 ⁷ / ₈	6 ⁷ / ₈	1	22 ¹ / ₁₆	5 ¹ / ₂	5 ¹ / ₂	73
	3	50DLU61.5	1.5	2	18 ³ / ₁₆	10 ³ / ₁₆	12 ⁵ / ₈	5 ¹ / ₁₆	9 ⁵ / ₈	7 ⁷ / ₈	13 ¹³ / ₁₆	26 ¹ / ₁₆	7 ¹ / ₁₆	6 ⁵ / ₁₆	106
		80DLU61.5	1.5	2	20 ⁷ / ₁₆	11 ¹ / ₂	15	5 ³ / ₄	11 ¹ / ₄	8 ¹¹ / ₁₆	13 ¹³ / ₁₆	26 ⁷ / ₈	8 ¹ / ₄	7 ¹ / ₈	121
	4	100DLU61.5	1.5	2	21 ¹³ / ₁₆	10 ¹ / ₂	16 ⁹ / ₁₆	5 ¹ / ₄	12	10 ¹³ / ₁₆	13 ¹³ / ₁₆	28 ⁵ / ₁₆	7 ⁷ / ₈	8 ⁹ / ₁₆	143

Dimensions: mm

PHASE	SIZE ø	MODEL	OUTPUT		PUMP & MOTOR										WEIGHT kg
			kW	HP	A	B	C	D	E	F	G	H	J	L	
SINGLE	50	50DLU6.75S	0.75	1	393	222	283	110	205	175	25	542	150	140	35
		50DLU61.5S	1.5	2	462	258	321	129	245	200	20	576	180	160	44
	80	80DLU61.5S	1.5	2	519	292	381	146	285	220	20	597	210	181	51
		80DLU62.2S	2.2	3	605	335	436	169	340	250	20	721	235	206	77
	100	80DLU63.7S	3.7	5	605	335	436	169	340	250	20	767	235	206	80
		100DLU61.5S	1.5	2	554	267	420	134	305	275	20	633	200	217	61
		100DLU62.2S	2.2	3	581	282	440	141	325	275	25	735	220	220	72
		100DLU63.7S	3.7	5	581	282	440	141	325	275	25	781	220	220	83
THREE	50	100DLMU63.7S	3.7	5	624	335	455	169	340	250	8	808	235	205	95
		50DLU6.75	0.75	1	393	222	283	110	205	175	25	561	140	140	33
	80	50DLU61.5	1.5	2	462	258	321	129	245	200	20	662	180	160	48
		80DLU61.5	1.5	2	519	292	381	146	285	220	20	683	210	181	55
100	100DLU61.5	1.5	2	554	267	420	134	305	275	20	719	200	217	65	



Dimensions

Project: _____ Model: _____ Chk'd: _____ Date: _____

Model DLU, Single and Three Phase
80DLMU, 2 to 5 HP

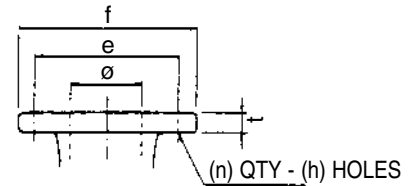
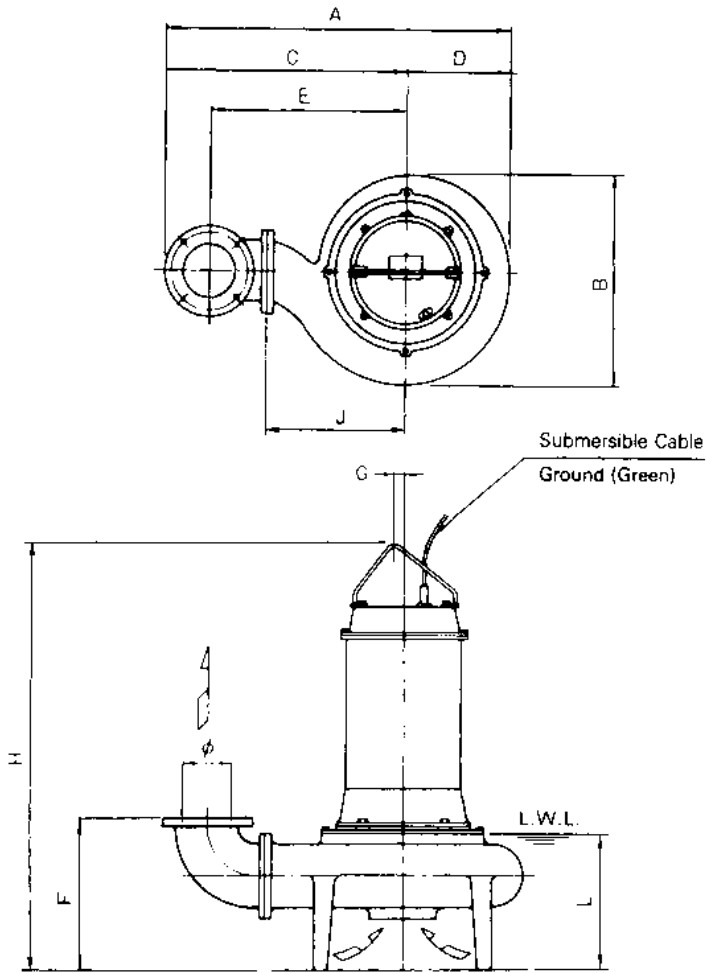

Flange (ANSI 125 PSI F.F)

inch					
ø	e	f	t	n	h
3	6	7 ¹ / ₂	³ / ₄	4	³ / ₄
4	7 ¹ / ₂	9	¹⁵ / ₁₆	8	³ / ₄

mm					
ø	e	f	t	n	h
80	152	191	19	4	19
100	191	229	24	8	19

Dimensions: inch

PHASE	SIZE ø	MODEL	OUTPUT		PUMP & MOTOR										WEIGHT Lb
			kW	HP	A	B	C	D	E	F	G	H	J	L	
SINGLE	3	80DLMU61.5S	1.5	2	20 ⁷ / ₁₆	11 ¹ / ₈	14 ⁷ / ₈	5 ³ / ₁₆	11 ¹ / ₄	8 ¹¹ / ₁₆	¹³ / ₁₆	23 ¹ / ₂	8 ¹ / ₄	7 ¹ / ₈	121
		80DLMU62.2S	2.2	3	20 ⁵ / ₈	11 ¹ / ₂	14 ⁷ / ₈	5 ³ / ₄	11 ¹ / ₄	8 ¹¹ / ₁₆	¹³ / ₁₆	27 ¹¹ / ₁₆	8 ¹ / ₄	7 ³ / ₈	148
		80DLMU63.7S	3.7	5	21 ⁵ / ₁₆	12 ¹ / ₈	15 ¹ / ₄	6 ¹ / ₁₆	11 ⁵ / ₈	8 ¹¹ / ₁₆	¹³ / ₁₆	29 ⁷ / ₁₆	8 ¹¹ / ₁₆	7 ³ / ₈	172
THREE	3	80DLMU61.5	1.5	2	20 ⁷ / ₁₆	11 ¹ / ₂	14 ⁷ / ₈	5 ³ / ₄	11 ¹ / ₄	8 ¹¹ / ₁₆	¹³ / ₁₆	26 ⁷ / ₈	8 ¹ / ₄	7 ¹ / ₈	130

Dimensions: mm

PHASE	SIZE ø	MODEL	OUTPUT		PUMP & MOTOR										WEIGHT kg
			kW	HP	A	B	C	D	E	F	G	H	J	L	
SINGLE	80	80DLMU61.5S	1.5	2	519	282	378	141	285	220	20	597	210	181	55
		80DLMU62.2S	2.2	3	524	292	378	146	285	220	20	703	210	188	67
		80DLMU63.7S	3.7	5	542	308	388	154	295	220	20	748	220	187	78
THREE	80	80DLMU61.5	1.5	2	519	292	378	146	285	220	20	683	210	181	59



Dimensions

Project: _____ Model: _____ Chk'd: _____ Date: _____

Model DLU with Quick Discharge Connector, Single Phase

50DLU, 1 to 2HP

80DLU, 2 to 5HP

100DLU, 2 to 5HP

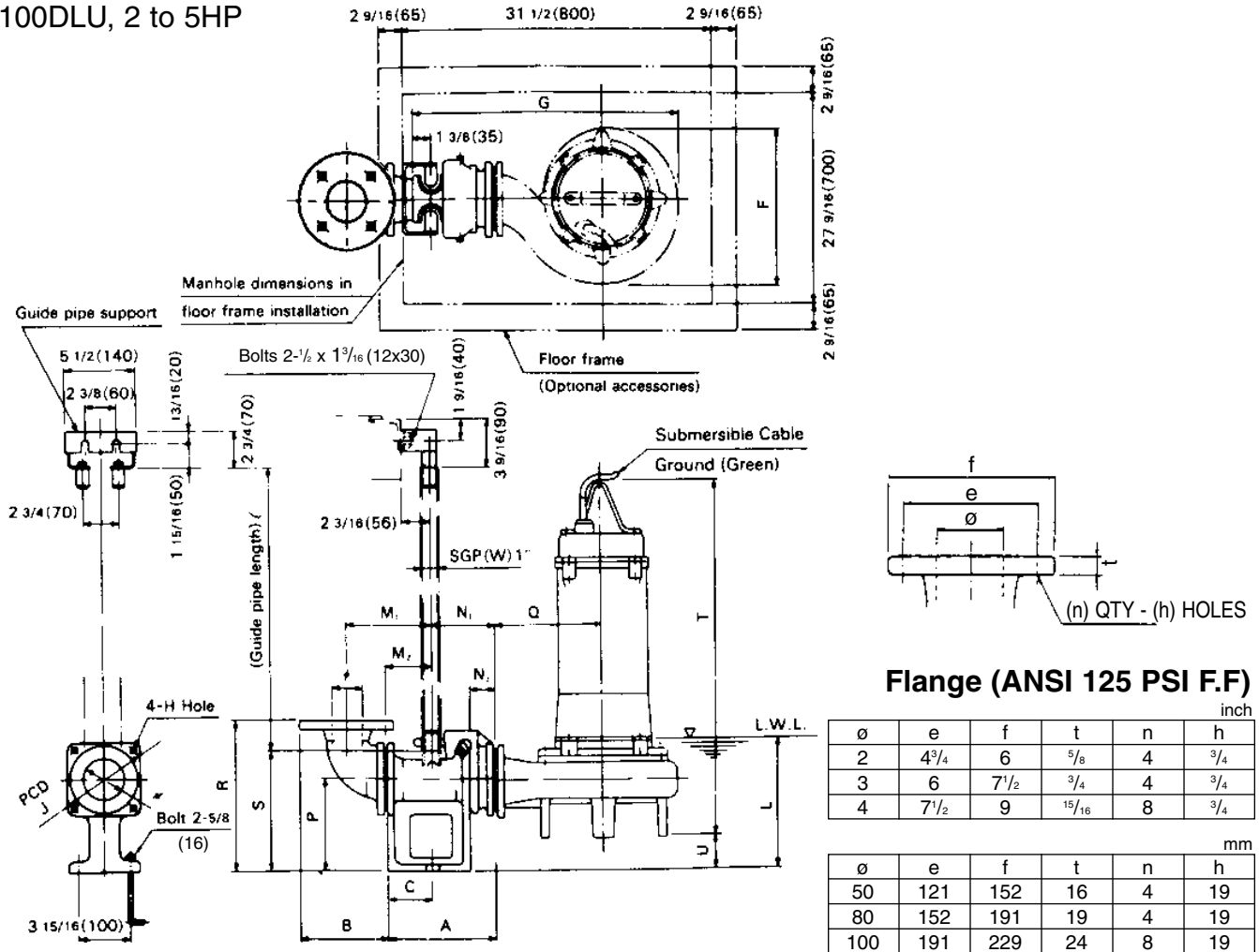

Flange (ANSI 125 PSI F.F)

inch						
ø	e	f	t	n	h	
2	4 ³ / ₄	6	5 ⁵ / ₈	4	3 ³ / ₄	
3	6	7 ¹ / ₂	3 ³ / ₄	4	3 ³ / ₄	
4	7 ¹ / ₂	9	1 ⁵ / ₁₆	8	3 ³ / ₄	

mm						
ø	e	f	t	n	h	
50	121	152	16	4	19	
80	152	191	19	4	19	
100	191	229	24	8	19	

Dimensions: inch

PHASE	SIZE ø	PUMP MODEL	OUTPUT kW HP	QDC MODEL	QDC											PUMP & MOTOR						WEIGHT Lb			
					A	B	C	H	J	M ₁	M ₂	N ₁	N ₂	P	R	S	F	G	L	Q	T	U	PUMP	QDC	
SINGLE	2	50DLU6.75S	0.75	1	LM50	7 ¹¹ / ₁₆	5 ¹ / ₄	3 ³ / ₈	1 ¹ / ₂	4 ³ / ₄	5 ⁹ / ₁₆	3 ³ / ₈	4 ¹ / ₂	1 ¹ / ₁₆	5 ⁵ / ₁₆	9 ¹ / ₁₆	6 ¹ / ₂	8 ³ / ₄	16 ¹ / ₈	7 ¹¹ / ₁₆	5 ⁷ / ₈	21 ⁹ / ₁₆	2 ³ / ₁₆	77	24
		50DLU61.5S	1.5	2	LM65	8 ⁷ / ₁₆	6	3 ³ / ₄	1 ¹ / ₂	5 ¹ / ₂	6 ⁵ / ₁₆	3 ³ / ₄	4 ³ / ₄	1 ¹ / ₄	5 ¹¹ / ₁₆	9 ⁹ / ₁₆	7 ¹ / ₂	10 ¹⁰ / ₁₆	18 ¹ / ₈	8 ¹ / ₄	7 ⁷ / ₁₆	22 ¹ / ₁₆	1 ¹⁵ / ₁₆	97	31
	3	80DLU61.5S	1.5	2	LM80	8 ⁷ / ₁₆	6 ⁵ / ₈	3 ⁹ / ₁₆	9 ¹ / ₁₆	6 ¹ / ₈	6 ¹ / ₂	3 ⁹ / ₁₆	4 ¹⁵ / ₁₆	1 ¹⁵ / ₁₆	6 ⁷ / ₈	11 ¹ / ₄	9 ¹ / ₁₆	11 ¹ / ₂	20 ¹ / ₈	9 ¹ / ₁₆	8 ¹ / ₄	23 ¹ / ₂	2 ⁹ / ₁₆	112	37
		100DLU61.5S	1.5	2	LM80	8 ⁷ / ₁₆	8 ¹ / ₄	3 ⁹ / ₁₆	9 ¹ / ₁₆	6 ¹ / ₈	7 ¹¹ / ₁₆	3 ⁹ / ₁₆	4 ¹⁵ / ₁₆	1 ¹⁵ / ₁₆	6 ⁷ / ₈	11 ¹³ / ₁₆	9 ¹ / ₁₆	10 ¹ / ₂	19 ¹ / ₁₆	9 ¹ / ₂	7 ⁷ / ₈	24 ¹⁵ / ₁₆	1	134	37
	4	100DLU62.2S	2.2	3	LM80	8 ⁷ / ₁₆	8 ¹ / ₄	3 ⁹ / ₁₆	9 ¹ / ₁₆	6 ¹ / ₈	7 ¹¹ / ₁₆	3 ⁹ / ₁₆	4 ¹⁵ / ₁₆	1 ¹⁵ / ₁₆	6 ⁷ / ₈	11 ¹³ / ₁₆	9 ¹ / ₁₆	11 ¹ / ₈	20 ¹ / ₂	9 ⁵ / ₈	8 ¹ / ₁₆	28 ¹⁵ / ₁₆	1	159	37
		100DLU63.7S	3.7	5	LM80	8 ⁷ / ₁₆	8 ¹ / ₄	3 ⁹ / ₁₆	9 ¹ / ₁₆	6 ¹ / ₈	7 ¹¹ / ₁₆	3 ⁹ / ₁₆	4 ¹⁵ / ₁₆	1 ¹⁵ / ₁₆	6 ⁷ / ₈	11 ¹³ / ₁₆	9 ¹ / ₁₆	11 ¹ / ₈	20 ¹ / ₂	9 ⁵ / ₈	8 ¹ / ₁₆	30 ³ / ₄	1	183	37

Dimensions: mm

PHASE	SIZE ø	PUMP MODEL	OUTPUT kW HP	QDC MODEL	QDC											PUMP & MOTOR						WEIGHT kg			
					A	B	C	H	J	M ₁	M ₂	N ₁	N ₂	P	R	S	F	G	L	Q	T	U	PUMP	QDC	
SINGLE	50	50DLU6.75S	0.75	1	LM50	195	133	80	12	120	135	80	115	40	135	230	165	222	410	195	150	542	55	35	11
		50DLU61.5S	1.5	2	LM65	215	153	95	12	140	160	95	120	45	145	250	190	258	464	210	180	576	50	44	14
	80	80DLU61.5S	1.5	2	LM80	215	168	90	15	155	165	90	125	50	175	285	230	292	511	246	210	597	65	51	17
		100DLU61.5S	1.5	2	LM80	215	210	90	15	155	195	90	125	50	175	300	230	267	494	242	200	633	25	61	17
	100	100DLU62.2S	2.2	3	LM80	215	210	90	15	155	195	90	125	50	175	300	230	282	521	245	220	735	25	72	17
		100DLU63.7S	3.7	5	LM80	215	210	90	15	155	195	90	125	50	175	300	230	282	521	245	220	781	25	83	17



Contents

Project: _____ Model: _____ Chk'd: _____ Date: _____

Model DLU with Quick Discharge Connector, Three Phase

50DLU, 1 to 2HP

80DLU, 2HP

100DLU, 2HP

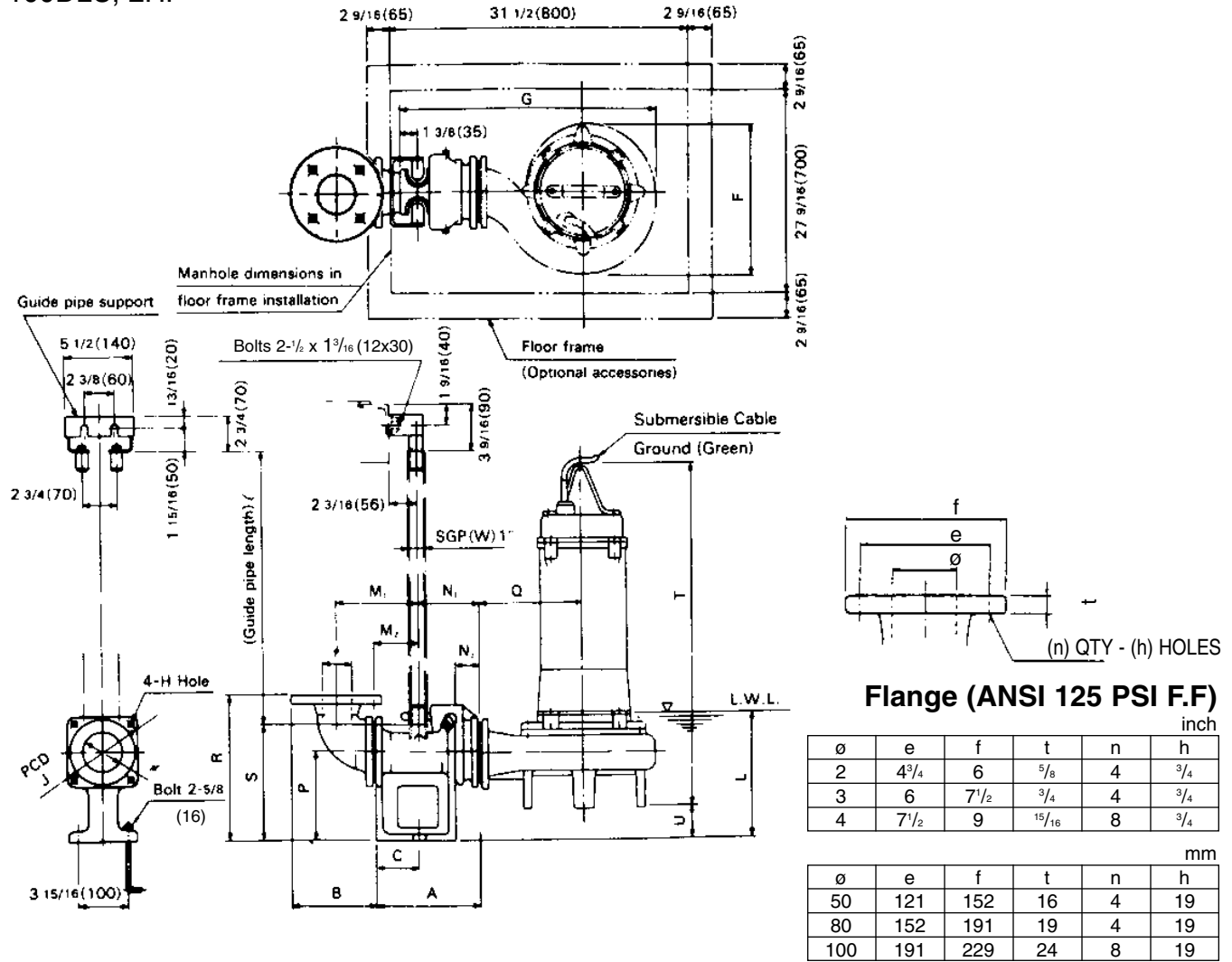

Dimensions: inch

PHASE	SIZE ø	PUMP MODEL	OUTPUT		QDC MODEL	QDC										PUMP & MOTOR						WEIGHT Lb			
			KW	HP		A	B	C	H	J	M ₁	M ₂	N ₁	N ₂	P	R	S	F	G	L	Q	T	U	PUMP	QDC
SINGLE	2	50DLU6.75	0.75	1	LM50	7 ^{11/16}	5 ^{1/4}	3 ^{3/8}	1/2	4 ^{3/4}	5 ^{9/16}	3 ^{1/8}	4 ^{1/2}	1 ^{9/16}	5 ^{5/16}	9 ^{1/16}	6 ^{1/2}	8 ^{3/4}	16 ^{5/8}	7 ^{11/16}	5 ^{7/8}	22 ^{1/16}	2 ^{9/16}	73	24
		50DLU61.5	1.5	2	LM65	8 ^{7/16}	6	3 ^{3/4}	1/2	5 ^{1/2}	6 ^{9/16}	3 ^{3/4}	4 ^{3/4}	1 ^{3/4}	5 ^{11/16}	9 ^{9/16}	7 ^{1/2}	10 ^{9/16}	18 ^{1/4}	8 ^{1/4}	7 ^{1/16}	26 ^{1/16}	1 ^{15/16}	106	31
	3	80DLU61.5	1.5	2	LM80	8 ^{7/16}	6 ^{5/8}	3 ^{9/16}	9/16	6 ^{1/8}	6 ^{1/2}	3 ^{9/16}	4 ^{15/16}	1 ^{15/16}	6 ^{7/8}	11 ^{1/4}	9 ^{1/16}	11 ^{1/2}	20 ^{5/8}	9 ^{1/16}	8 ^{1/4}	26 ^{7/8}	2 ^{9/16}	121	37
		100DLU61.5	1.5	2	LM80	8 ^{7/16}	8 ^{1/4}	3 ^{9/16}	9/16	6 ^{1/8}	7 ^{11/16}	3 ^{9/16}	4 ^{15/16}	1 ^{15/16}	6 ^{7/8}	11 ^{13/16}	9 ^{1/16}	10 ^{1/2}	19 ^{1/16}	9 ^{1/2}	7 ^{7/8}	28 ^{5/16}	1	143	37

Dimensions: mm

PHASE	SIZE ø	PUMP MODEL	OUTPUT		QDC MODEL	QDC										PUMP & MOTOR						WEIGHT kg			
			KW	HP		A	B	C	H	J	M ₁	M ₂	N ₁	N ₂	P	R	S	F	G	L	Q	T	U	PUMP	QDC
THREE	50	50DLU6.75	0.75	1	LM50	195	133	80	12	120	135	80	115	40	135	230	165	222	410	195	150	561	55	33	11
		50DLU61.5	1.5	2	LM65	215	153	95	12	140	160	95	120	45	145	250	190	258	464	210	180	662	50	48	14
	80	80DLU61.5	1.5	2	LM80	215	168	90	15	155	165	90	125	50	175	285	230	292	511	246	210	683	65	55	17
		100DLU61.5	1.5	2	LM80	215	210	90	15	155	195	90	125	50	175	300	230	267	494	242	200	719	25	65	17



Dimensions

Project: _____ Model: _____ Chk'd: _____ Date: _____

Model DLU with Quick Discharge Connector, Single and Three Phase
 80DLMU, 2 to 5 HP

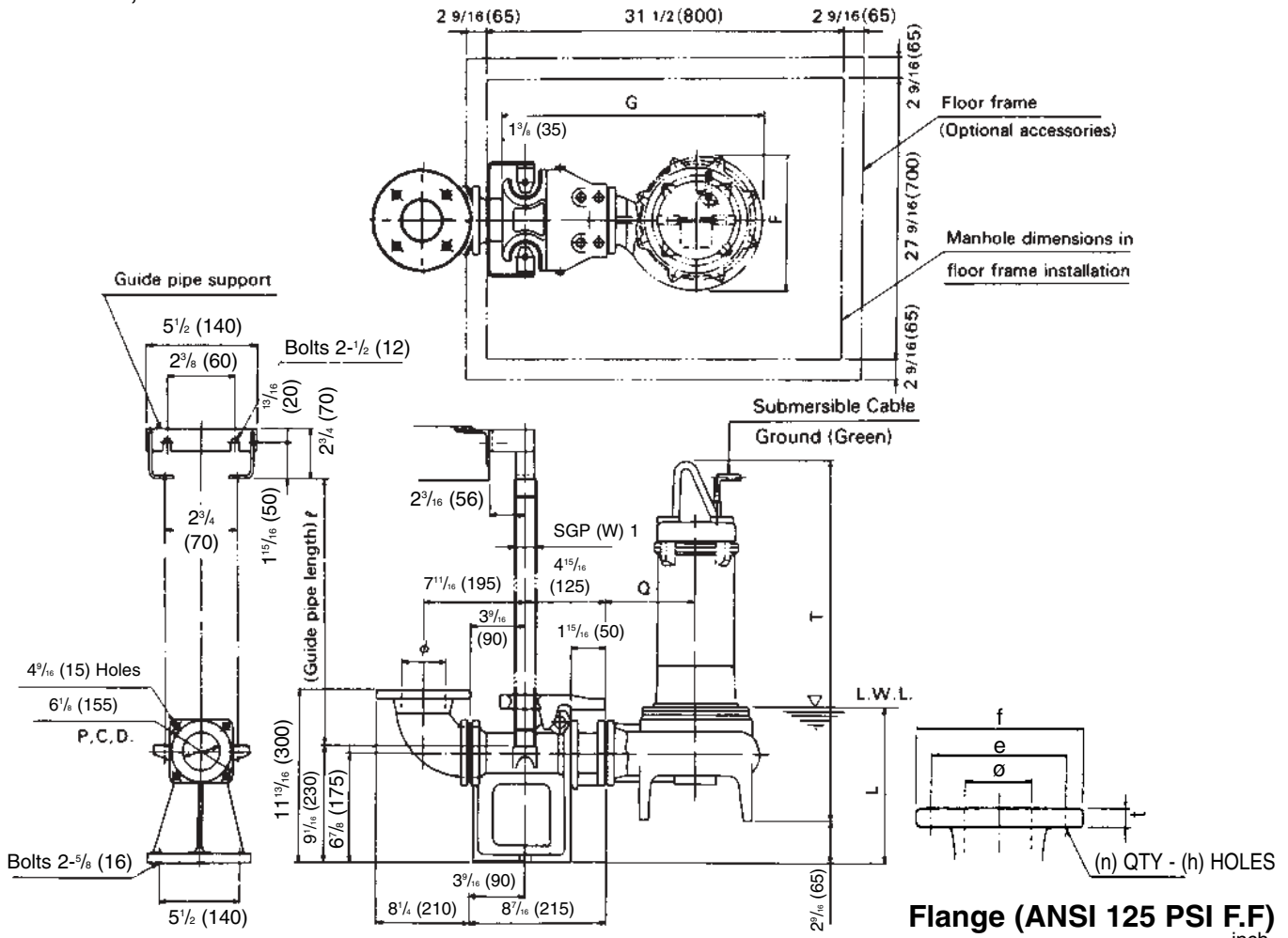

Flange (ANSI 125 PSI F.F.)

inch	ø	e	f	t	n	h
3	6	7 1/2	3/4	4	3/4	
4	7 1/2	9	15/16	8	3/4	

mm	ø	e	f	t	n	h
80	152	191	19	4	19	
100	191	229	24	8	19	

Dimensions: inch

PHASE	SIZE ø	PUMP MODEL	OUTPUT		QDC MODEL	PUMP & MOTOR					WEIGHT Lb	
			kW	HP		F	G	L	Q	T	PUMP	QDC
SINGLE	3	80DLMU61.5S	1.5	2	LM80	11 1/8	20 1/8	9 11/16	8 1/4	23 1/2	121	37
		80DLMU62.2S	2.2	3	LM80	11 1/2	20 5/16	9 15/16	8 1/4	27 11/16	148	37
		80DLMU63.7S	3.7	5	LM80	12 1/8	21	9 15/16	8 1/16	29 7/16	172	37
THREE	3	80DLMU61.5	1.5	2	LM80	11 1/8	20 1/8	9 11/16	8 1/4	26 7/8	130	37

Dimensions: mm

PHASE	SIZE ø	PUMP MODEL	OUTPUT		QDC MODEL	PUMP & MOTOR					WEIGHT kg	
			kW	HP		F	G	L	Q	T	PUMP	QDC
SINGLE	80	80DLMU61.5S	1.5	2	LM80	282	511	246	210	597	55	17
		80DLMU62.2S	2.2	3	LM80	292	516	253	210	703	67	17
		80DLMU63.7S	3.7	5	LM80	308	534	252	220	748	78	17
THREE	80	80DLMU61.5	1.5	2	LM80	282	511	246	210	683	59	17



Dimensions

Project: _____ Model: _____ Chk'd: _____ Date: _____

Model DLU with Quick Discharge Connector, Single Phase

80DLU, 3 to 5HP

100DLMU, 5HP

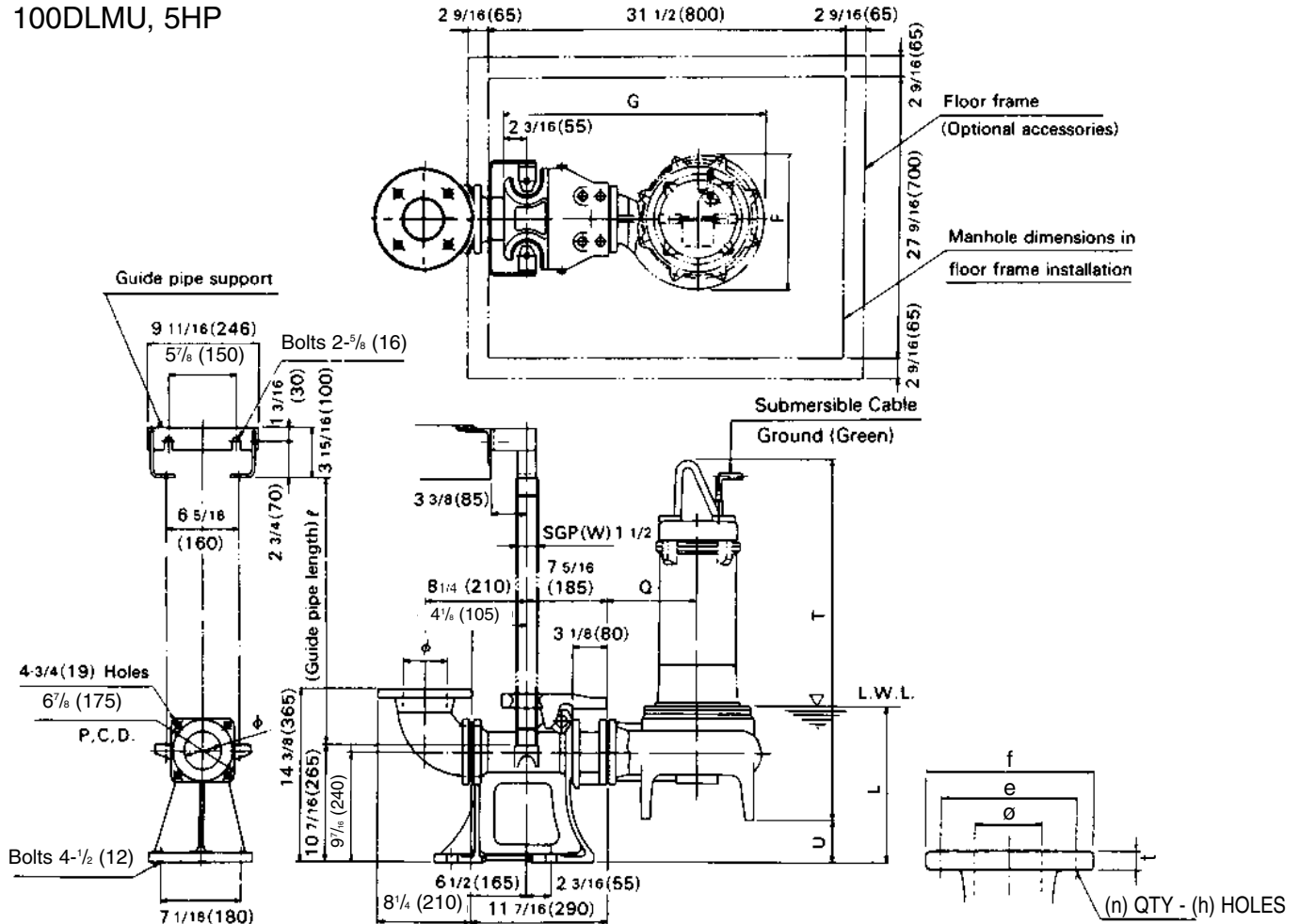

Flange (ANSI 125 PSI F.F)

inch					
ø	e	f	t	n	h
3	6	7 1/2	3/4	4	3/4
4	7 1/2	9	15/16	8	3/4

mm					
ø	e	f	t	n	h
80	152	191	19	4	19
100	191	229	24	8	19

Dimensions: inch

PHASE	SIZE ø	PUMP MODEL	OUTPUT		QDC MODEL	PUMP & MOTOR					WEIGHT Lb		
			kW	HP		F	G	L	Q	T	U	PUMP	QDC
SINGLE	3	80DLU62.2S	2.2	3	LL100	13 ³ / ₁₆	25 ³ / ₈	12 ⁵ / ₈	9 ¹ / ₄	28 ³ / ₈	4 ¹ / ₂	170	101
		80DLU63.7S	3.7	5	LL100	13 ³ / ₁₆	25 ³ / ₈	12 ⁵ / ₈	9 ¹ / ₄	30 ³ / ₁₆	4 ¹ / ₂	177	101
	4	100DLMU63.7S	3.7	5	LL100	13 ³ / ₁₆	25 ³ / ₈	12 ⁵ / ₈	9 ¹ / ₄	36 ⁵ / ₁₆	4 ¹ / ₂	209	101

Dimensions: mm

PHASE	SIZE ø	PUMP MODEL	OUTPUT		QDC MODEL	PUMP & MOTOR					WEIGHT kg		
			kW	HP		F	G	L	Q	T	U	PUMP	QDC
SINGLE	80	80DLU62.2S	2.2	3	LL100	335	644	321	235	721	115	77	46
		80DLU63.7S	3.7	5	LL100	335	644	321	235	767	115	80	46
	100	100DLMU63.7S	3.7	5	LL100	335	644	320	235	923	115	95	46



Sectional View

Project: _____ Model: _____ Chk'd: _____ Date: _____

Single Phase
1 to 5HP

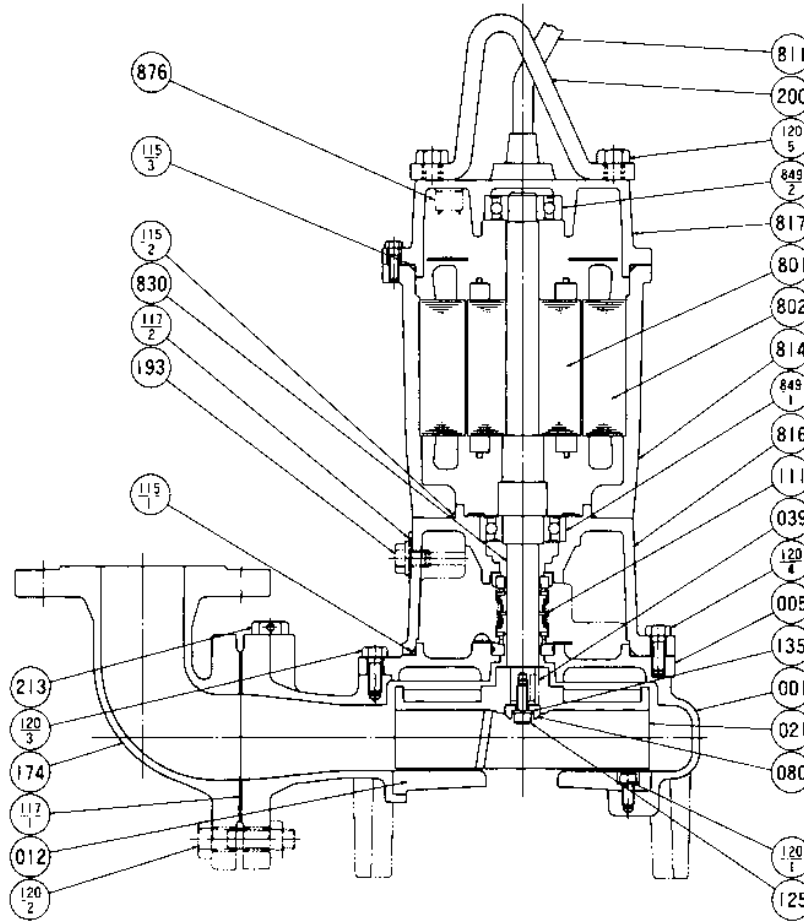

PART NO.	PART NAME	MATERIAL	ASTM, AISI CODE	NO. FOR 1 UNIT	PART NO.	PART NAME	MATERIAL	ASTM, AISI CODE	NO. FOR 1 UNIT
001	CASING	CAST IRON	A48 Class 30	1	125	BOLT	304 STAINLESS	AISI304	1
005	INTERMEDIATE CASING	CAST IRON	A48 Class 30	1	135	WASHER	304 STAINLESS	AISI304	1
012	SUCTION COVER	CAST IRON	A48 Class 30	1	174	DISCHARGE ELBOW	CAST IRON	A48 Class 30	1
021	IMPELLER	CAST IRON	A48 Class 30	1	193	OIL PLUG	316 STAINLESS	AISI316	1
039	KEY	420 STAINLESS	AISI420	1	200	LIFTING HANGER	STEEL	A283 Grade D	1
080	BUSHING	STEEL	A283 Grade D	1	213	AIR VENT VALVE	BRASS	B36 NO. 272	1
†111	MECHANICAL SEAL	—		1 SET	801	ROTOR	—		1
†115-1	O-RING	RUBBER (NBR)		1	802	STATOR	—		1
†115-2	O-RING	RUBBER (NBR)		1	811	SUBMERSIBLE CABLE	—		1
†115-3	O-RING	RUBBER (NBR)		1	814	MOTOR FRAME	CAST IRON	A48 Class 30	1
†117-1	GASKET			1	816	BRACKET	CAST IRON	A48 Class 30	1
†117-2	GASKET			1	817	BRACKET	CAST IRON	A48 Class 30	1
120-1	BOLT	304 STAINLESS	AISI304	3 or 4	830	SHAFT	403 STAINLESS	AISI403	1
120-2	BOLT	304 STAINLESS	AISI304	4	†849-1	BALL BEARING	—		1
120-3	BOLT	304 STAINLESS	AISI304	4 or 8	†849-2	BALL BEARING	—		1
120-4	BOLT	304 STAINLESS	AISI304	4	876	MOTOR PROTECTOR	—		1
120-5	BOLT	304 STAINLESS	AISI304	2					

Motors are purchased as a complete unit.

†: Recommended spare parts.



Sectional View

Project: _____ Model: _____ Chk'd: _____ Date: _____

Three Phase
1 to 2HP

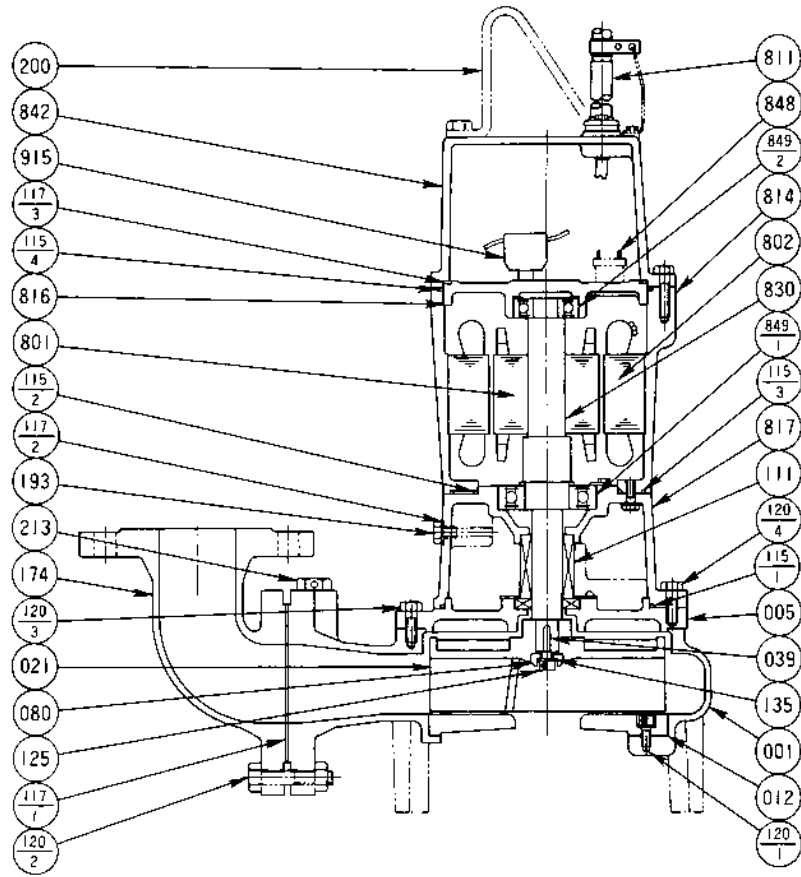

PART NO.	PART NAME	MATERIAL	ASTM, AISI CODE	NO. FOR 1 UNIT
001	CASING	CAST IRON	A48 Class 30	1
005	INTERMEDIATE CASING	CAST IRON	A48 Class 30	1
012	SUCTION COVER	CAST IRON	A48 Class 30	1
021	IMPELLER	CAST IRON	A48 Class 30	1
039	KEY	420 STAINLESS	AISI420	1
080	BUSHING	STEEL	A283 Grade D	1
†111	MECHANICAL SEAL	—		1 SET
†115-1	O-RING	RUBBER (NBR)		1
†115-2	O-RING	RUBBER (NBR)		1
†115-3	O-RING	RUBBER (NBR)		1
†115-4	O-RING	RUBBER (NBR)		1
†117-1	GASKET			1
†117-2	GASKET			1
†117-3	GASKET	RUBBER (NBR)		1
120-1	BOLT	304 STAINLESS	AISI304	3 or 4
120-2	BOLT	304 STAINLESS	AISI304	4
120-3	BOLT	304 STAINLESS	AISI304	4 or 8
120-4	BOLT	304 STAINLESS	AISI304	4

PART NO.	PART NAME	MATERIAL	ASTM, AISI CODE	NO. FOR 1 UNIT
125	BOLT	304 STAINLESS	AISI304	1
135	WASHER	304 STAINLESS	AISI304	1
174	DISCHARGE ELBOW	CAST IRON	A48 Class 30	1
193	OIL PLUG	316 STAINLESS	AISI316	1
200	LIFTING HANGER	STEEL	A283 Grade D	1
213	AIR VENT VALVE	BRASS	B36 NO. 272	1
801	ROTOR	—		1
802	STATOR	—		1
811	SUBMERSIBLE CABLE	—		1
814	MOTOR FRAME	CAST IRON	A48 Class 30	1
816	BRACKET	CAST IRON	A48 Class 30	1
817	BRACKET	CAST IRON	A48 Class 30	1
830	SHAFT	403 STAINLESS	AISI403	1
842	MOTOR COVER	CAST IRON	A48 Class 30	1
848	MOTOR PROTECTOR	—		1
†849-1	BALL BEARING	—		1
†849-2	BALL BEARING	—		1
915	EXTERNAL TERMINAL	—		1

Motors are purchased as a complete unit.
 Parts No. 115-2 is not installed for 2HP
 Parts No. 117-3 is not installed for 1HP
 †: Recommended spare parts.

