

**Myers®**

# 3WHV, V3WHV Non-Clog Pumps Installation and Service Manual

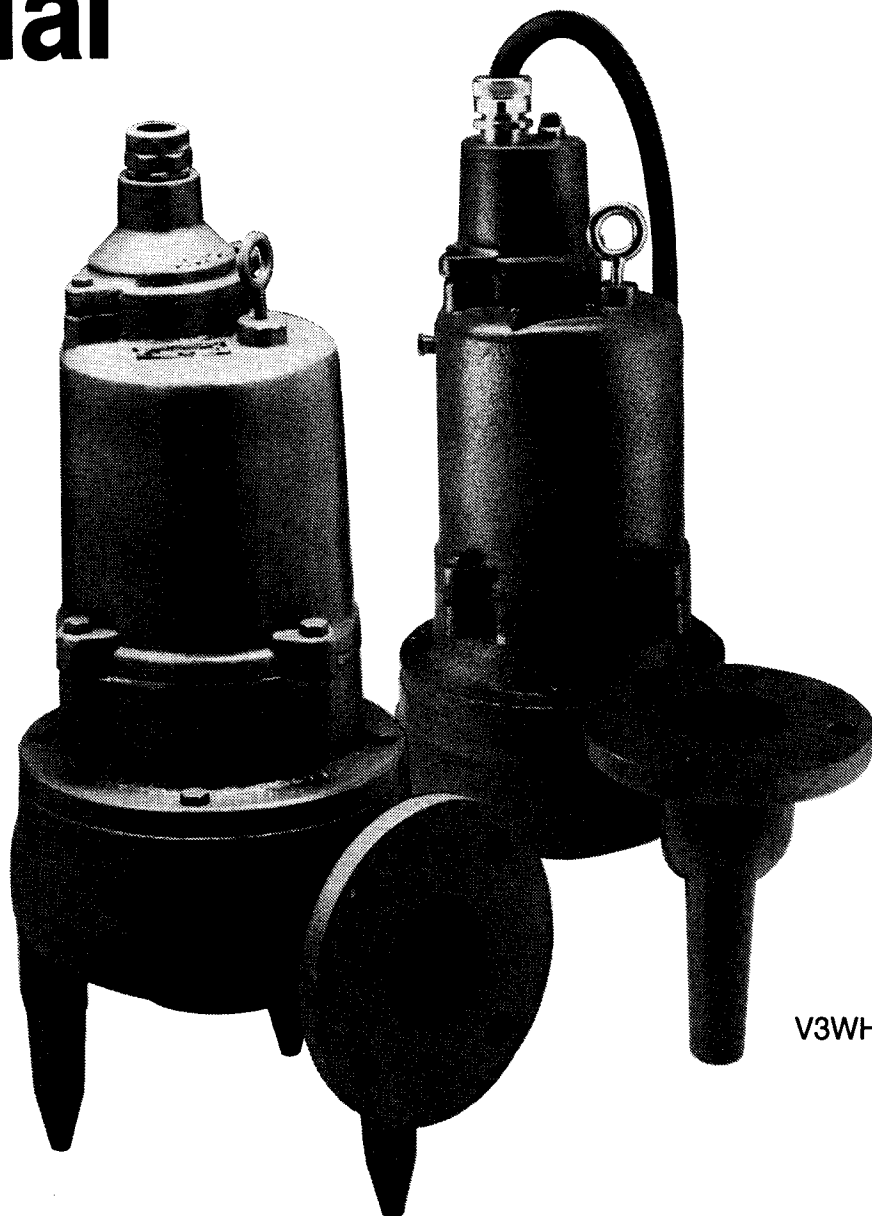

3WHV

V3WHV

# 3WHV & V3WHV CROSS-SECTION

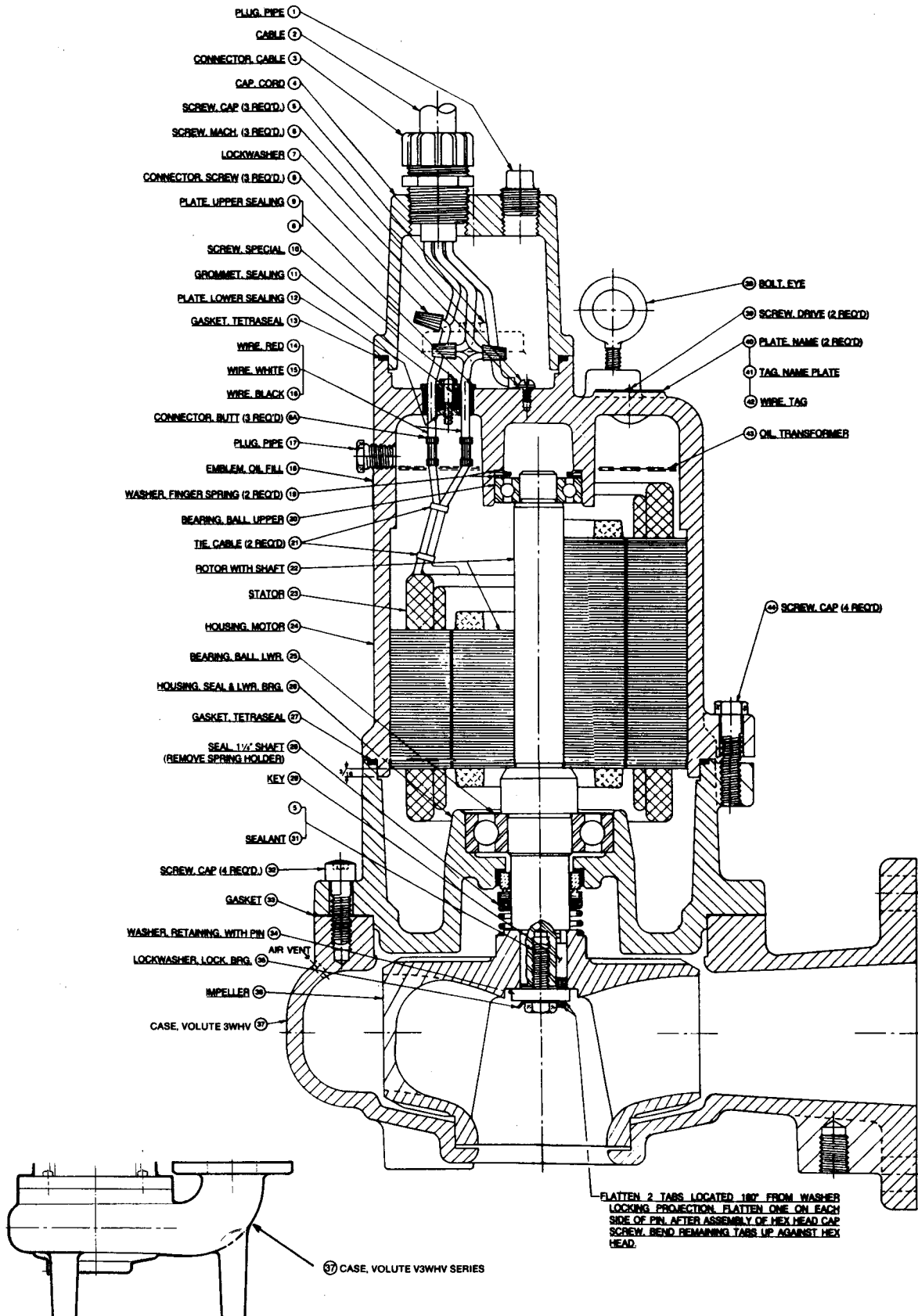
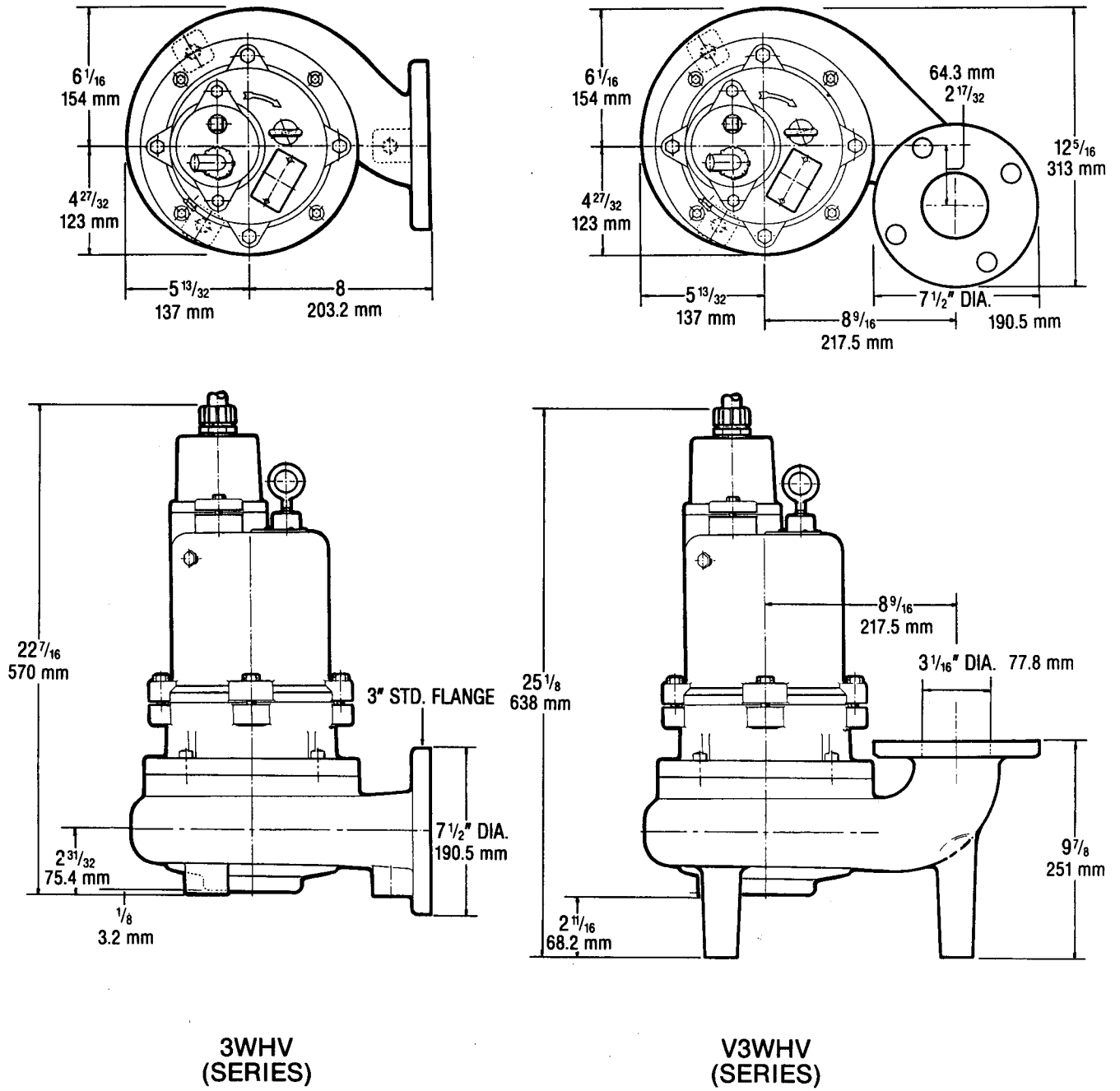

Fig. 1

### 3WHV & V3WHV PUMP DIMENSIONS



**3WHV  
(SERIES)**

**V3WHV  
(SERIES)**

Fig. 2

## PUMP MODELS

These instructions cover the installation and service of the 3WHV and V3WHV series of non-clog pumps and guide rail systems for the horizontal discharge models only. These models are designed for handling raw sewage and waste water. Do not use for acid waste water. The pumps have 2-vane, non-clog impellers. The 3WHV and V3WHV will pass 2 1/2" dia. solids and has a 3" std. flange discharge. Drawing Fig. 1 shows a cross-sectional view of the pump. Drawing Fig. 2 shows the overall dimensions of each pump.

**CAUTION:** In the initial installation, before sewage is admitted to wet well, there is no danger on entering the sump, but after sewage has been in the sump there is **danger**. Sewage water gives off methane and hydrogen sulfide gases, both of which are highly poisonous. Never enter wet well unless cover is open and an outside blower is used to force fresh air into the wet well. Also, the man in the wet well should wear a harness with rope to surface so that he can be pulled out in case of asphyxiation. One man should not work alone.

## HEAT SENSOR

The 3WHV and V3WHV single phase pump motors contain internally wired line break overloads, while the 3WHV and V3WHV three phase pumps do not have heat sensors. Any motor temperature above the sensor rating will open the overload and stop the motor. The overload will automatically close upon cooling.

**CAUTION:** The single phase pumps will restart without warning as the motor cools. Therefore, **never** do service work on the pump unless power supply is disconnected.

## MOTOR POWER CABLE AND CONTROL CABLE

Each power cord has 4 conductors — white, black, red and green. For 3 phase, the red, black and white conductors connect to the 3 line terminals and the green is connected to a good outside ground such as a ground rod at least 8 feet into soil. Interchanging any two of the three power conductors will reverse a 3 phase motor.

For single phase, the white and black leads connect to the two line terminals and the red connects to the start winding terminal. The green is for ground and must be connected to a good outside ground. See Fig. 3.

**CAUTION:** Never pull pump or work on control box until incoming power is disconnected. Never run motor until green ground conductor is connected to a good outside ground. Never pull on electrical cables to lift pump.

Power cables attached to the pumps are No. 10 gauge wire. If the control panel is located at a distance from the pump, consult Table 3 for permissible wire gauge to run between control panel and the junction box at the wet well. Wire gauge No. 10 may be used for all pump models located within 200 feet of the control panel.

## OIL FILLED MOTOR

The motor chamber is dielectric oil filled for good heat transfer and lubrication of bearings. The motor requires no other oiling or greasing. Oil level in the motor housing should be to the bottom of the oil fill plug with the pump in a vertical position. Do not over fill the motor housing since some space is required for oil expansion. See Fig. 1 for oil levels. Transformer oil SOHIO Factopure SE40 should be used and may be purchased from your Myers dealer.

## AIR VENTING

Upon initial filling of the wet well with the water, air may be trapped in the pump volute. To vent off this air a 5/32" diameter hole is located in the volute. **BE SURE THIS VENT HOLE IS CLEAN AFTER ANY SERVICE WORK ON PUMP.**

**PUMP MODEL TABULATION**

**WINDING RESISTANCE**

Model No.	HP	RPM	PH	V	Amps	Locked Rotor Amperes	Starting Code	Main BL-W	Start BL-R	W-R
3WHV10M4-21 V3WHV10M4-21	1	1750	1	230	8	50	J	1.55	1.57	3.12
3WHV10M4-03 V3WHV10M4-03	1	1750	3	200	5.4	36	K	2.07	2.07	2.07
3WHV10M4-23 V3WHV10M4-23	1	1750	3	230	4.5	32	K	2.69	2.69	2.69
3WHV10M4-43 V3WHV10M4-43	1	1750	3	460	2.3	19	M	10.75	10.75	10.75
3WHV10M4-53 V3WHV10M4-53	1	1750	3	575	1.8	13	J	19.10	19.10	19.10
3WHV15M4-21 V3WHV15M4-21	1 1/2	1750	1	230	10	50	J	1.55	1.57	3.12
3WHV15M4-03 V3WHV15M4-03	1 1/2	1750	3	200	6.6	36	K	2.07	2.07	2.07
3WHV15M4-23 V3WHV15M4-23	1 1/2	1750	3	230	5.5	32	K	2.69	2.69	2.69
3WHV15M4-43 V3WHV15M4-43	1 1/2	1750	3	460	2.8	19	M	10.75	10.75	10.75
3WHV15M4-53 V3WHV15M4-53	1 1/2	1750	3	575	2.2	13	K	19.10	19.10	19.10
3WHV20M4-01 V3WHV20M4-01	2	1750	1	208	15	78	J	1.18	3.90	5.08
3WHV20M4-21 V3WHV20M4-21	2	1750	1	230	12	64	J	2.43	3.40	5.83
3WHV20M4-03 V3WHV20M4-03	2	1750	3	200	8.4	44	J	2.21	2.21	2.21
3WHV20M4-23 V3WHV20M4-23	2	1750	3	230	7	40	J	2.05	2.05	2.05
3WHV20M4-43 V3WHV20M4-43	2	1750	3	460	3.5	23	L	8.20	8.20	8.20
3WHV20M4-53 V3WHV20M4-53	2	1750	3	575	2.8	16	J	15.65	15.65	15.65
3WHV30M4-21 V3WHV30M4-21	3	1750	1	230	21	101	J	.83	2.38	3.21
3WHV30M4-03 V3WHV30M4-03	3	1750	3	200	15	66	J	1.29	1.29	1.29
3WHV30M4-23 V3WHV30M4-23	3	1750	3	230	12	58	J	1.46	1.46	1.46
3WHV30M4-43 V3WHV30M4-43	3	1750	3	460	6	29	J	5.80	5.80	5.80
3WHV30M4-53 V3WHV30M4-53	3	1750	3	575	5	21	H	11.15	11.15	11.15
3WHV50M4-21 V3WHV50M4-21	5	1750	1	230	34	101	J	.83	2.38	3.21
3WHV50M4-03 V3WHV50M4-03	5	1750	3	200	24	66	J	.74	.74	.74
3WHV50M4-23 V3WHV50M4-23	5	1750	3	230	21	58	J	.89	.89	.89
3WHV50M4-43 V3WHV50M4-43	5	1750	3	460	10.5	29	J	3.54	3.54	3.54
3WHV50M4-53 V3WHV50M4-53	5	1750	3	575	8.4	21	H	5.69	5.69	5.69

TABLE 1

**ELECTRICAL COMPONENTS SINGLE PHASE ONLY**

Model No.	H.P.	Start Cap. No.	Run Cap. No.	Start Relay, No.
3WHV10M4-21 V3WHV10M4-21	1	12141A007 110 VAC 1020-1224 MFD	12749A004 370 Volt 15 MFDS	21990A003 (40 Amp) PU, FL 150-160 DO, VL 40
3WHV15M4-21 V3WHV15M4-21	1 1/2	12141A007 110 VAC 1020-1224 MFD	23749A004 370 Volt 15 MEDS	21990A003 (40 Amp) PU, VL 150-160 DO, VL 40
3WHV20M4-01 V3WHV20M4-01	2	12141A012 220 VAC 574-688 MFD	23186A000 410 Volt 25 MFDS	21990A010 (16.7 Amp) PU, VL 250-270 DO, VL 110
3WHV20M4-21 V3WHV20M4-21	2	12141A006 220 VAC 270-324 MFD	19076A000 361-430 Volt 20 MFDS	21990A002 (33 Amp) PU, VL 300-320 DO, VL 100
3WHV30M4-21 V3WHV30M4-21	3 & 5	12141A008 220 VAC 430-516 MFD	23839A000 370 Volt 30 MFDS	21990A004 (43 Amp) PU, VL 290-310 DO, VL 95

TABLE 2

**CABLE SIZE REQUIRED DEPENDING ON MOTOR HORSEPOWER,  
VOLTAGE, AND DISTANCE OF CONTROL PANEL FROM PUMP**

Motor Horsepower	Phase	Voltage	MAX. OFFSET DISTANCE (FEET) PER WIRE GA.				
			14 A.W.G.	12 A.W.G.	10 A.W.G.	8 A.W.G.	6 A.W.G.
1	1	230	292	465	740	1175	1870
1½	1	230	245	385	615	980	1560
2	1	208	140	225	355	565	900
2	1	230	205	330	520	830	1320
3	1	230	153	245	385	615	980
5	1	230	92	145	230	370	590
1	3	200	315	500	790	1260	2000
1	3	230	430	685	1090	1730	2750
1	3	460	1720	2740	4360		
1	3	575	2690	4280			
1½	3	200	260	410	655	1040	1655
1½	3	230	345	545	870	1380	2195
1½	3	460	1375	2185	3475		
1½	3	575	2160	3435			
2	3	200	200	315	500	800	1275
2	3	230	260	420	665	1055	1680
2	3	460	1050	1670	2660		
2	3	575	1635	2600			
3	3	200	150	240	380	605	960
3	3	230	205	330	520	830	1320
3	3	460	825	1310	2085	3315	
3	3	575	1285	2050	3260		
5	3	200	110	170	270	430	690
5	3	230	150	235	375	600	950
5	3	460	595	947	1505	2395	3805
5	3	575	930	1480	2355	3740	

TABLE 3

3WHV & V3WHV WIRING DIAGRAMS

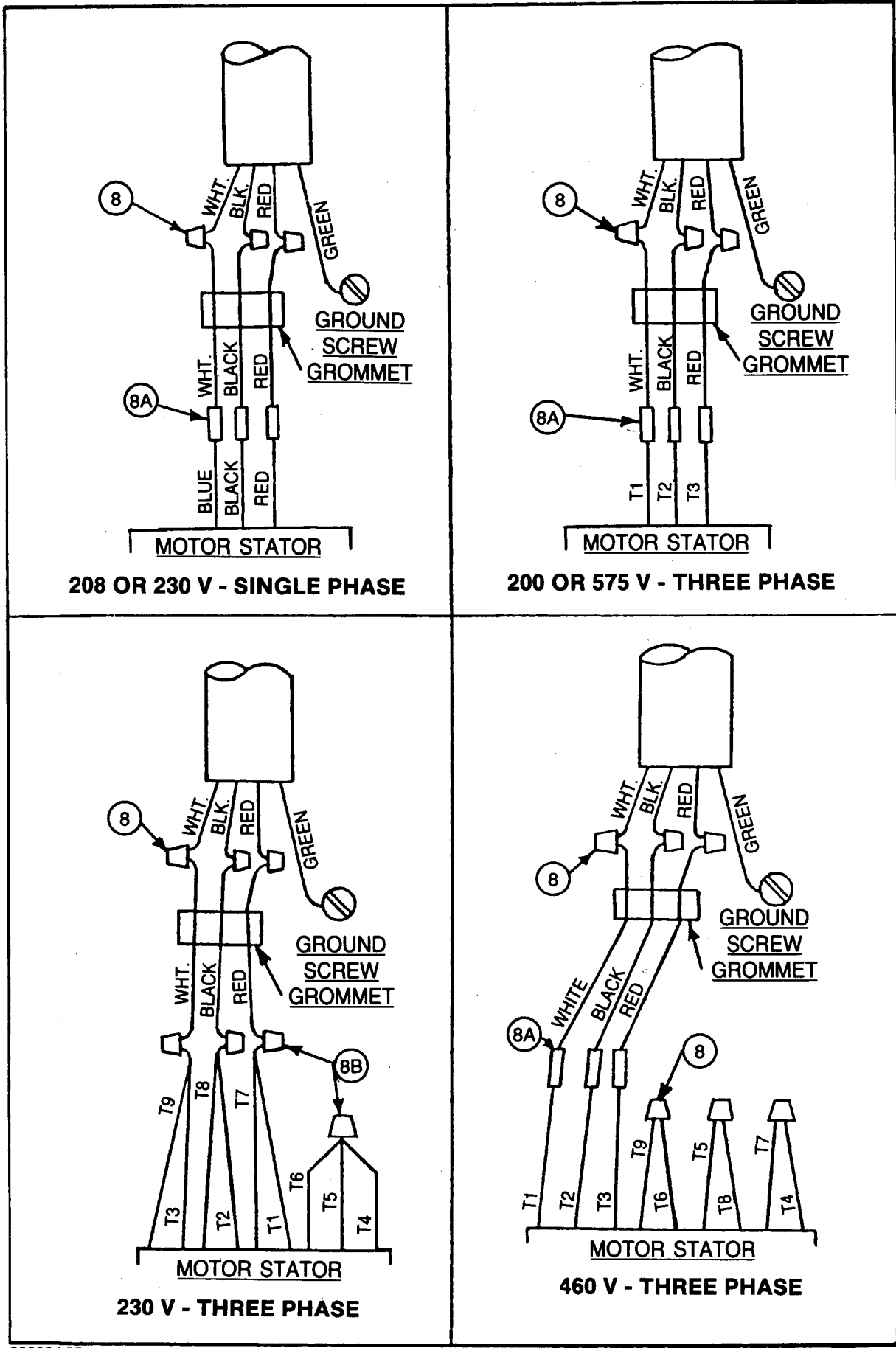

## INSTALLING RAIL SYSTEM PARTS

### (Horizontal Models Only)

#### MOUNTING COVER, DISCHARGE BASE & RAILS

1. Set concrete cover with hatch opening in position. If basin cover is to be steel or aluminum, secure the cover to basin walls with expansion bolts.
2. Bolt rail guide plates, Fig. 4 to frame. Stainless steel bolts are screwed through frame angles when shipped and nuts are provided to hold the plate. Brackets have vertical slots so that they can be adjusted for final fit on rails. The plate has slots so the two plates in a duplex system can be adjusted to obtain 16" center-to-center distance between pumps.
3. Lower the base or base/elbow assembly into the basin. **IMPORTANT** — Concrete bottom must be level and smooth for mounting discharge base. See Fig. 6.
4. Approximately position the base such that the pipe rail locating pins protruding from the top of the base are directly below the rail guides attached at the top of the basin; these rail guides should be positioned about mid-way in the vertical adjustment slots. Cut the pipe guide rails to length and install between the rail guides at the top of the basin and the pins on the base. Guide rails are  $\frac{3}{4}$ " Schedule 40, galvanized or stainless steel pipe.
5. Using a bubble level held against the rails, move the base until both rails are vertical. Now mark the position of the base, hold down bolts through the holes in the base.
6. Remove the guide rails and move the base aside to allow drilling of the concrete for  $\frac{5}{8}$ " expansion bolts  $2\frac{1}{2}$ " long. Then move the base over the bolt holes and re-install the guide rails. Recheck rails with bubble level and install the bolts.
7. Install discharge pipe as required by the particular job specifications. If one size larger discharge pipe is required, a reducing elbow may be attached to the base.
8. If the top rail guide plate can not be attached to the hatch cover frame, a special rail bracket (Fig. 5) can be furnished for mounting directly to a pipe cemented in the basin wall. This bracket is set and aligned with discharge base the same as described for the rail guide plate attached to the frame.

#### ATTACHING MOUNTING PLATE TO PUMP

1. With a gasket between the mounting plate and pump discharge, attach the mounting plate with the bolts supplied. See Fig. 6. The mounting plate should be turned so that two pins are horizontal and one pin vertical pointing up.

#### LOWERING PUMP TO DISCHARGE BASE

1. Attach lifting chains to eye bolts on top of the pump with the clevis furnished.
2. A hook is located on the top guide rail bracket to hold the upper end of the chain when not in use.
3. Check pump rotation if 3 phase. Connect power cords to motor control panel and lay pump on its side so that impeller can be seen. Turn all switches to off position.
4. Close main circuit breaker, then jog manual switch to ON then OFF. Note rotation direction of impeller. Impeller must turn counterclockwise as looking into the impeller's inlet. If rotation is wrong, interchange any two line leads to the motor. **BE SURE MAIN BREAKER IS OFF WHEN THIS CHANGE IS MADE. MARK WIRES SO THEY CAN BE REPLACED IN SAME ORDER.**
5. Mount the guide plate on the vertical pin of the mounting plate. Position the guide openings parallel with the face of the mounting plate. Snug the two set screws but do not overtighten at this time.
6. Slowly lower the pump down the guide rails to the base. Inspect the mating of the mounting plate face to the base face, they should be flat against one another. If necessary, loosen the two set screws of the guide plate and rotate the guide plate until an equal amount of clearance exists between the guide plate and the guide rails. Retighten the set screws. If no adjustment was necessary, check that the set screws are tight.
7. The pumps are now properly positioned for operation.



## TOP RAIL GUIDE PLATE FOR 3" & 4" LIFT-OUT SYSTEM

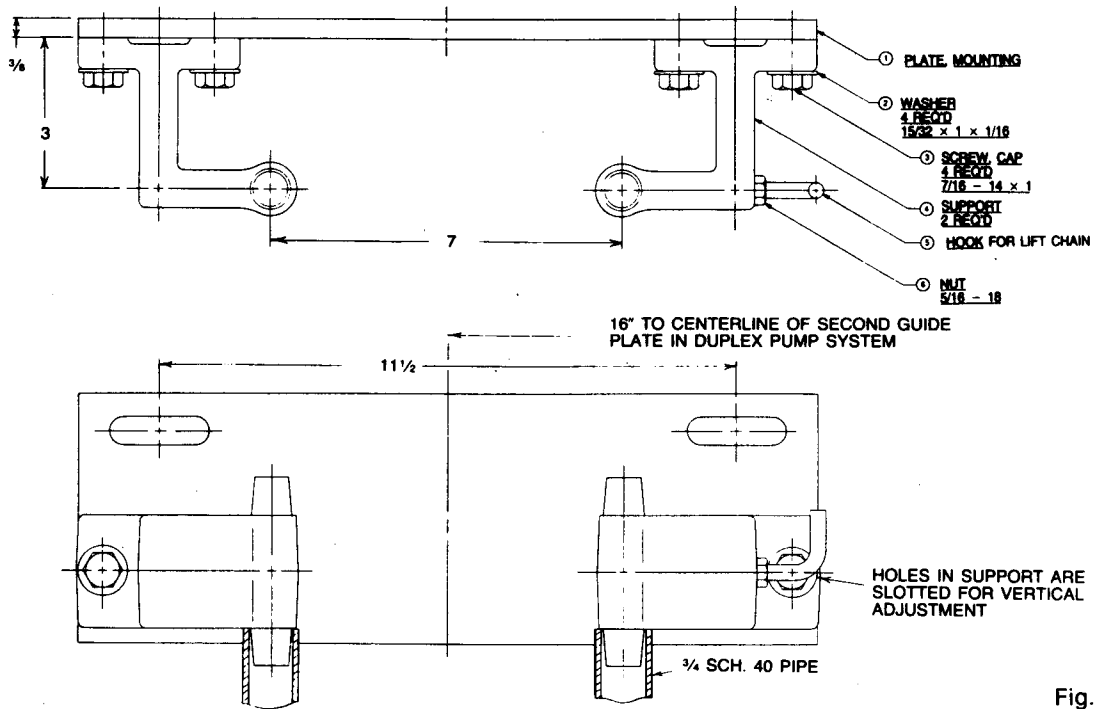

Fig. 4

## PIPE MOUNTED GUIDE RAIL BRACKET

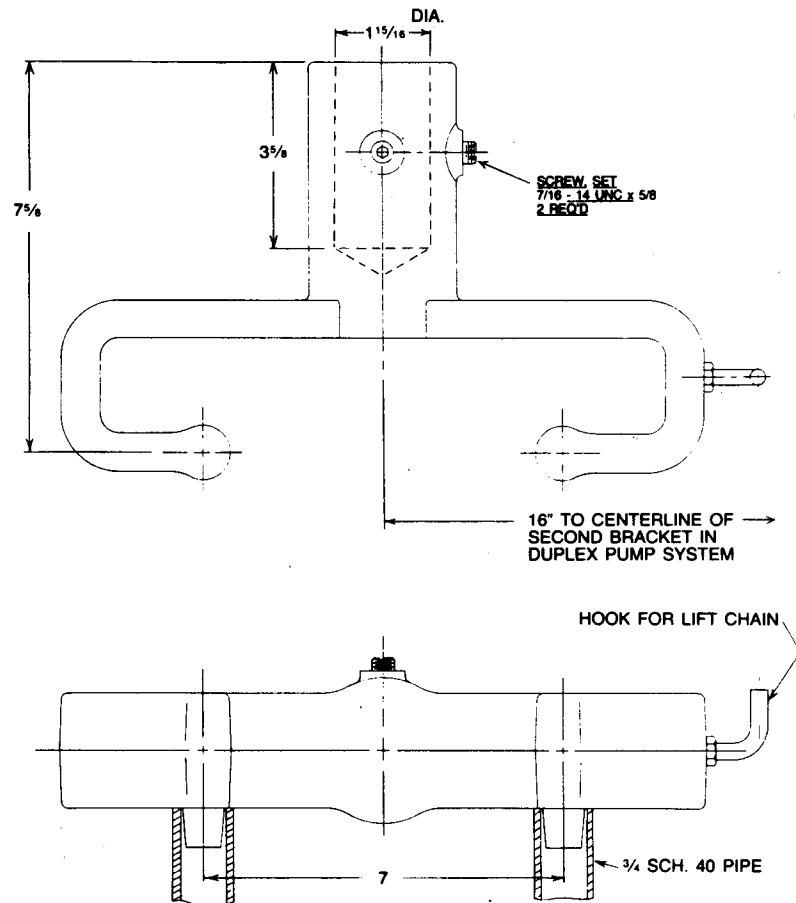

Fig. 5

# TYPICAL INSTALLATION

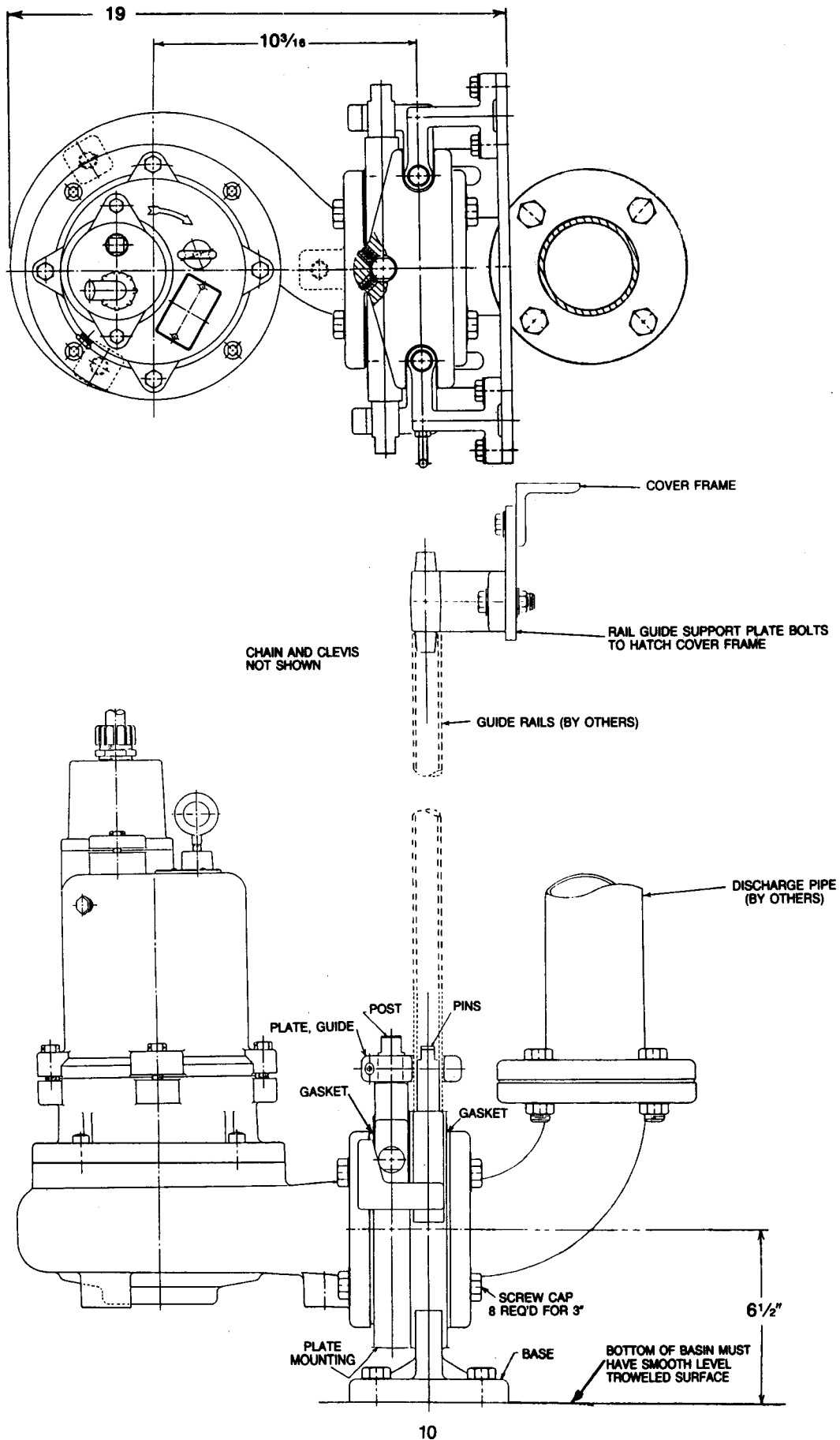
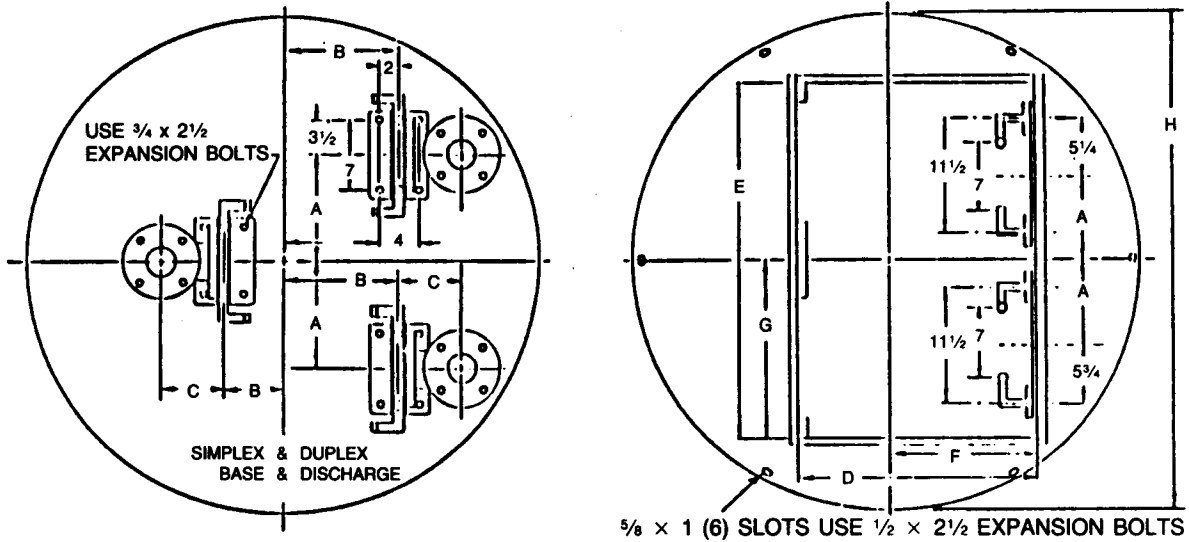

Fig. 6

23833A55

**INSTALLATION DIMENSIONS FOR 3WHV PUMPS,  
LIFT-OUT SYSTEM, HATCH AND COVER**



SURFACE BELOW FRAME MUST BE SMOOTH AND NOT PROTRUDE INTO FRAME OPENING.

HATCH ASSEMBLY TO BE CEMENTED IN PLACE WHEN BASIN TOP IS POURED. ANCHORS AND PLATE MTG. BOLT HEADS ARE CEMENTED INTO TOP.

Fig. 7

**INSTALLATION DIMENSIONS**

Pump	Disch.	Basin	Cover/Hatch	A	B	C	D	E	F	G	H
3WHV Simplex	3"	48"	HCD-48WHV, HCR-48HWV, HA-48WHV, HS-48WHV	0	5 <sup>7</sup> / <sub>8</sub>	6 <sup>5</sup> / <sub>16</sub>	23	36 <sup>1</sup> / <sub>2</sub>	9 <sup>1</sup> / <sub>4</sub>	18 <sup>1</sup> / <sub>4</sub>	54
3WHV Duplex	3"	60"	HCD-60, HCR-60 HA-60, HS-60	11	11 <sup>5</sup> / <sub>8</sub>	6 <sup>5</sup> / <sub>16</sub>	32	46	15	23	66

TABLE 4

TYPICAL INSTALLATION FOR DUPLEX SYSTEM  
WITH CONCRETE BASIN AND OUTSIDE VALVE BOX

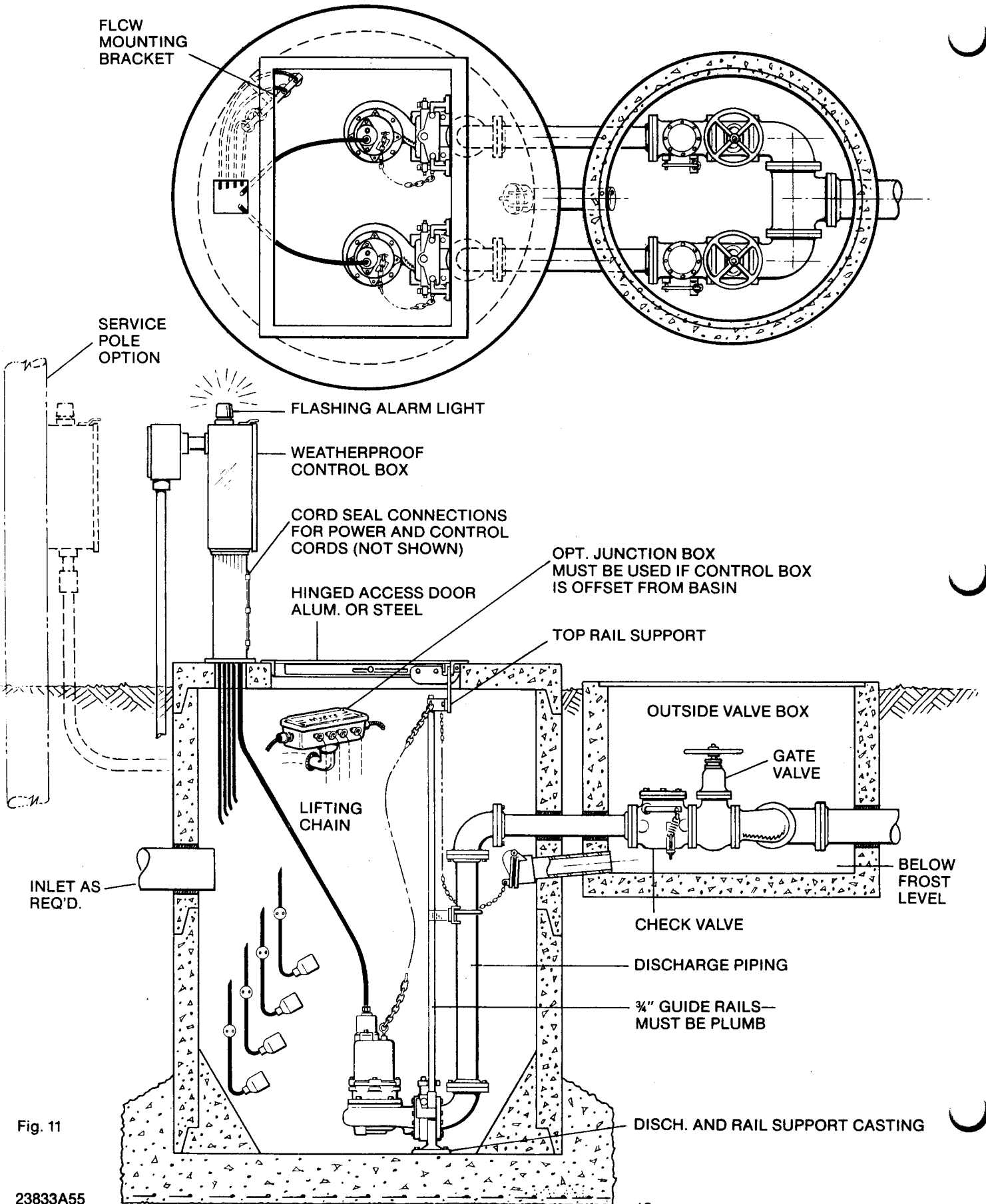

Fig. 11

## ELECTRICAL CONTROLS

(All Models)

### FLOAT SWITCH INSTALLATION

1. Level Controls are held by support bracket and cords are adjusted for proper depth.
  - a. Lower Turn-Off Control should be set so that pump stops when water level is about at the top of the volute.
  - b. First Turn-On Control is set to start pump when level is at height specified above pump.
  - c. Second Turn-On Control of a duplex pump system is set at height specified above first turn-on control.
  - d. Alarm Control is set about 6" to 12" above the highest Turn-On Control.
  - e. No Control should be set above basin inlet invert.

### MAKING ELECTRICAL CONNECTIONS

1. If control panel is mounted directly on basin top, the power and control wires are taken directly to control box and are sealed in the cord plate with cord grip connectors.
2. If panel is installed remote from basin, the cords can be taken through a conduit to control panel, or junction box can be used in the basin to make

connections. The Myers junction box has a built-in sealing connector to seal the outgoing wires. If other than Myers junction box is used, a separate sealing connector must be used where wires leave the basin. See Wiring Diagram Fig. 3.

**CAUTION:** If cords are taken directly through a conduit to control box, a seal fitting must be used at inlet of conduit to prevent gas vapors from getting to control box. This type of installation is generally not recommended because the sealing cement must be broken to remove a cord.

### MOTOR ELECTRICAL CONNECTIONS

Single phase motors are for 230 volts only. A special control panel with start and run capacitors and start relay are required for these pumps.

These control panels must be obtained from F.E. Myers or must be approved by Myers or warranty on motor is void. Also, warranty is void if the heat sensor and seal fixture wires are not connected properly to control box terminal strip.

**CAUTION:** Pump motor is not to be taken apart in the field. Motors under warranty must be serviced by Myers authorized repair station or be sent to factory.

# IN SUMP CONNECTION BOX, SIMPLEX SYSTEM, FLCW 3 BALL CONTROL

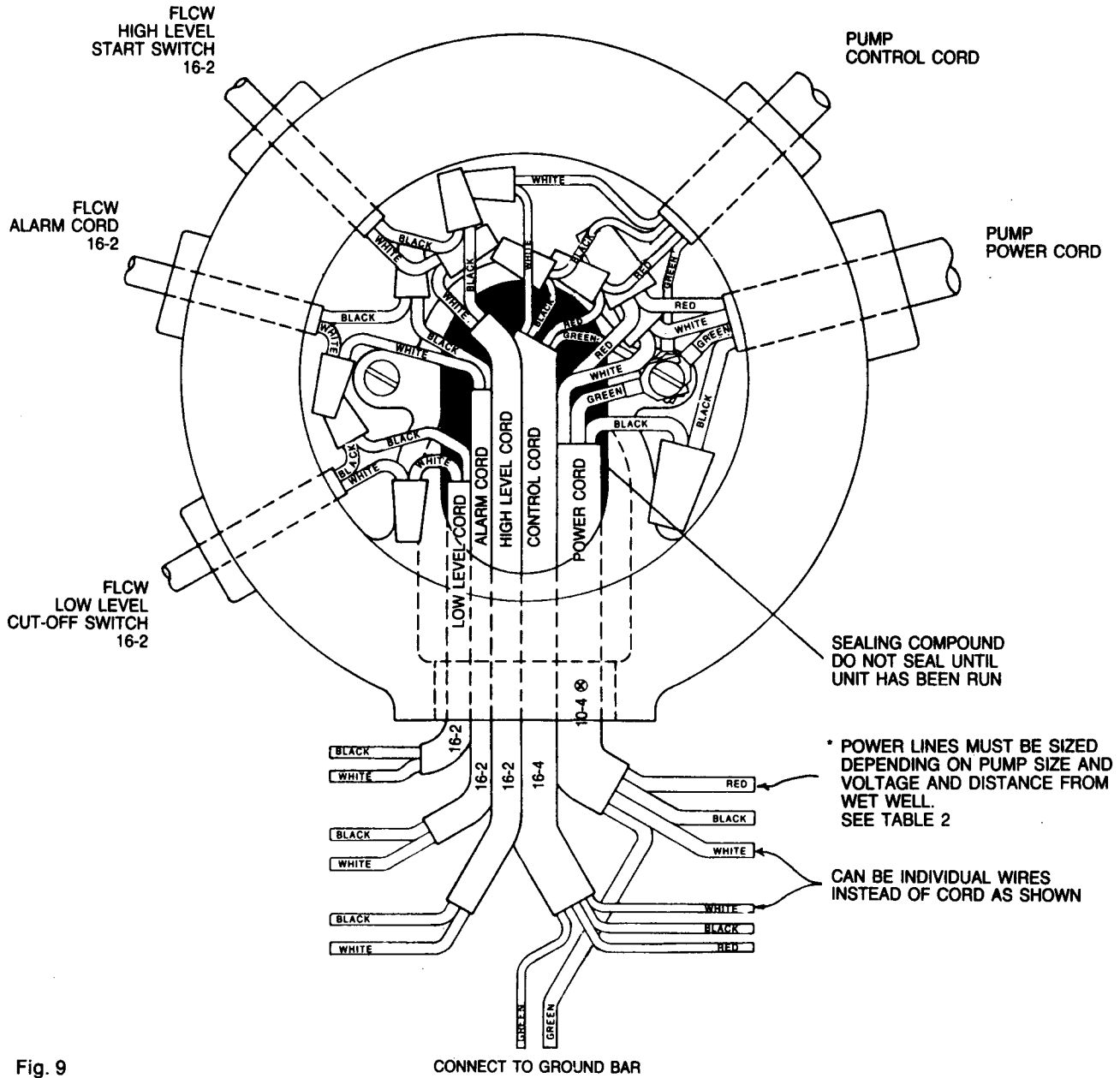

Fig. 9

# IN SUMP CONNECTION BOX, DUPLEX SYSTEM, FLCW 4 BALL CONTROL

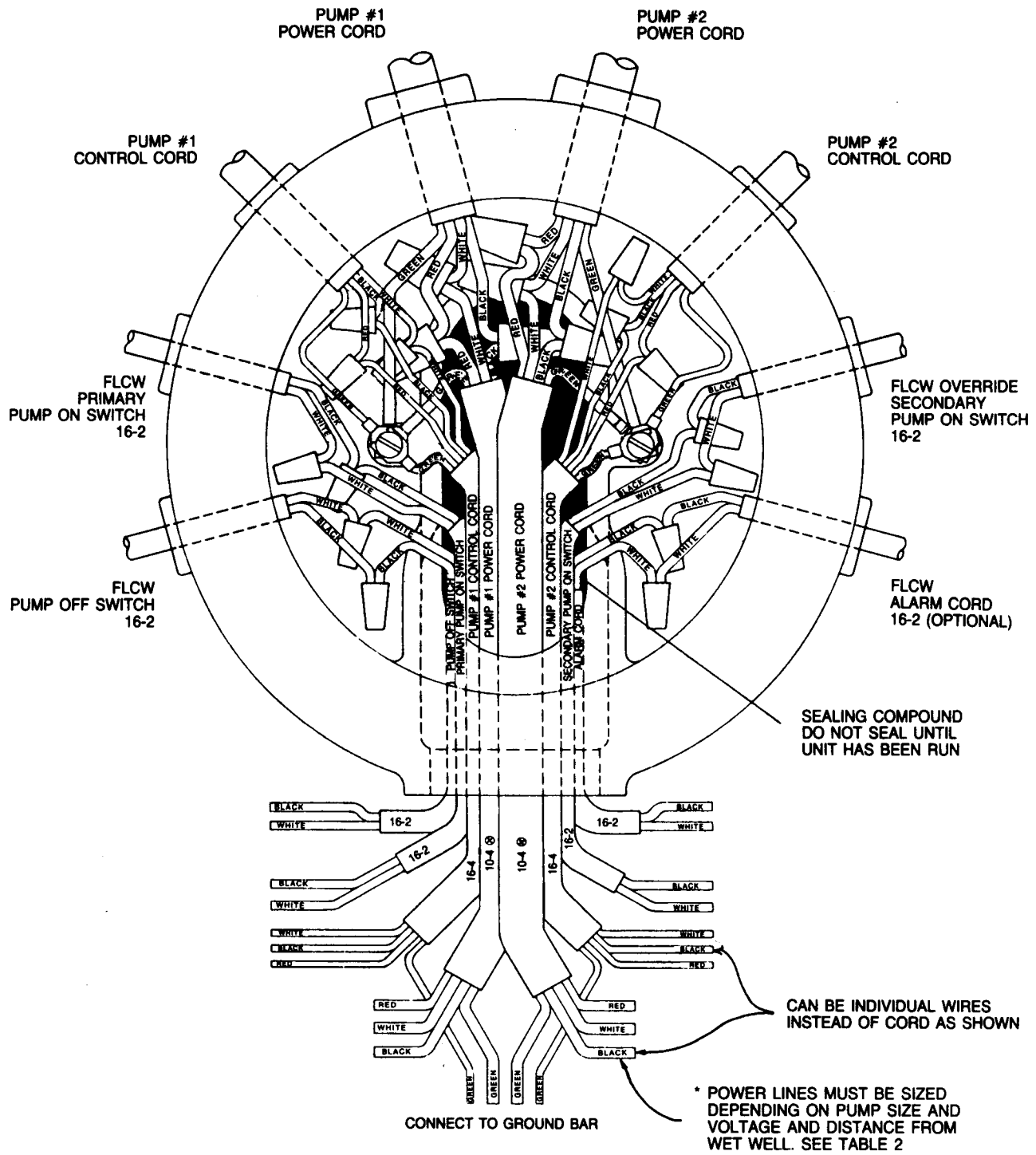

Fig. 10

## REMOVING PUMP CASE AND IMPELLER

In case of wear, damage due to dropping, plugged pump, or replacing a defective motor, the pump volute case and impeller can be removed in the field.

1. Remove bolts between seal housing flange and volute case. The motor and impeller can now be lifted off as a unit.
2. If necessary to remove impeller, lay pump on its side. With a screwdriver bend the tabs of the lockwasher away from the head of the hex head bolt.
3. Loosen and remove the bolt by turning counter-clockwise. Since Loctite™ is used to secure the bolt and on the shaft/impeller interface, heating of the shaft end to 450° to 500°F will usually be required.
4. Impeller is mounted by a straight fit with driving key. Pry evenly on opposite impeller sides with two large screwdrivers or small bars behind the impeller.
5. Set motor on end with shaft up after removing impeller so that oil will not drain past the seal.

## REPLACING IMPELLER AND PUMP CASE

1. Apply Loctite™ #680 before assembly, in keyway, in the impeller bore (lower shaft O.D.), and on the threads of the hex head cap screw.
2. Before placing the impeller on the shaft, be sure the mechanical seal and its spring are in place.
3. Position retaining washer with long pin extension in keyway.
4. Obtain a new lockwasher and flatten two tabs located 180° from the locking projection on the inner edge of the washer. There should be one flattened tab on each side of the pin extending from the retaining washer.
5. Assemble hex head cap screw and tighten securely.
6. Bend lockwasher tabs up against hex head of the bolt, do not bend up the two tabs flattened on each side of the pin in the retaining washer.

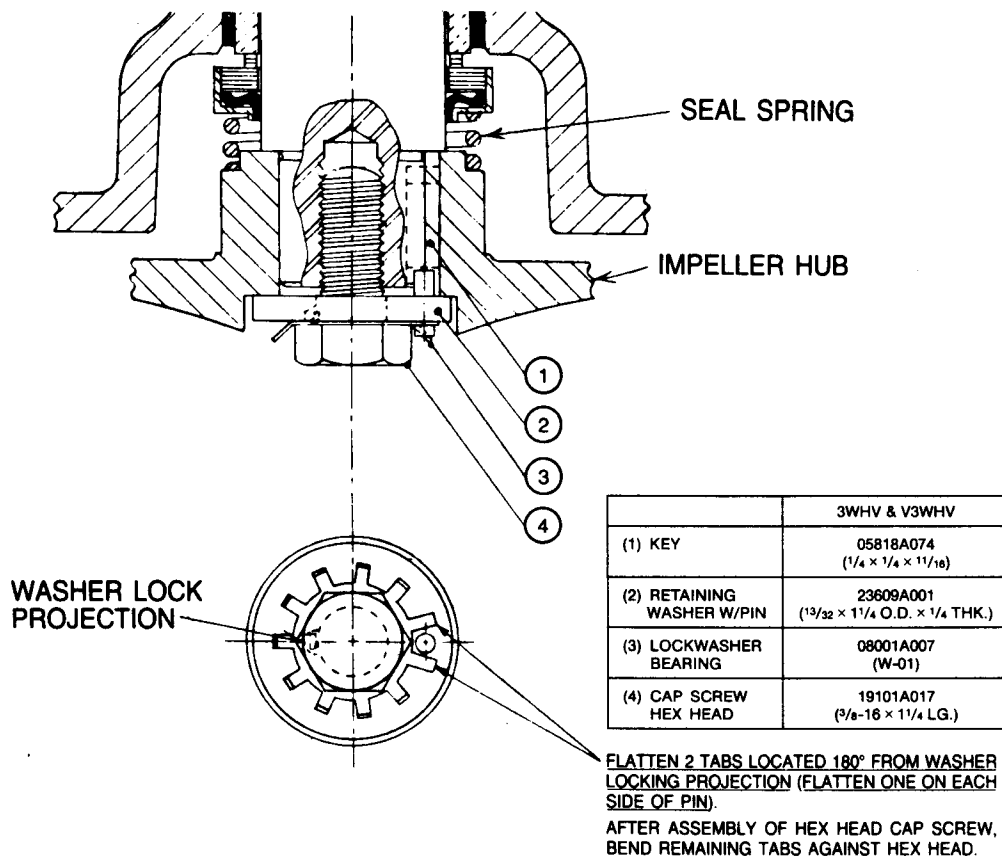

Fig. 8



## TROUBLE CHECK LIST

Troubles listed generally pertain to the pump and auxiliary components. Other troubles can occur from a faulty control box, these will be listed with the control box instructions.

### CONDITION

Pump runs but does not pump liquid from basin.

### PROBABLE CAUSE

1. Pump impeller may be air locked, this occasionally occurs on a new installation. Start and stop pump several times to purge air. Be sure air vent hole in volute case is clean. See Fig. 1.
2. Run additional water into basin so that pump will be submerged deeper to clear water.
3. If pump is three phase, rotation may be wrong. See instructions for checking proper rotation.
4. If pump has been installed for some time and does not pump, it may be clogged at inlet.
5. Discharge gate valve may be closed.
6. Discharge check valve may be clogged or have a broken clapper or spring.
7. Discharge head may be too high. Check elevation. Maximum pump head at zero flow is shown on pump curve sheet.
8. If above checks do not locate trouble, motor rotor may be loose on shaft which allows motor to run but will not turn impeller or only at low RPM.

---

Overload trips at control box and alarm buzzer or flashing red light comes on due to high water level in basin.

1. Push in on red reset button to reset overload. If overload trips again after short run, pump has some damage and must be removed from basin for checking.
2. Trouble may be from clogged impeller causing motor to overload or could be from failed motor.
3. Trouble may be from faulty component in control box. Always check control box before removing pump.

---

Yellow run light stays on continuously.

1. Indicates H-O-A switch may be in the hand position.
  2. Level control switch may have failed causing pump to continue to operate when water is below lower control.
  3. Impeller may be partially clogged, causing pump to operate at very reduced capacity.
  4. Gate valve or check valve may be clogged causing low pump flow.
  5. Pump may be air logged. Lift arm on check valve to vent off air. Also, check that the  $\frac{5}{32}$ " vent hole in the volute is open.
-

---

**CONDITION**

Circuit breaker trips.

**PROBABLE CAUSE**

1. Reset breaker by pushing clear down on handle then back to on position. If breaker trips again in a few seconds, it indicates excessive load which is probably caused by a short in the motor or control box. Check out instructions given with control box before pulling pump.
2. If this condition happens after an electrical storm motor or control box may be damaged by lightning.
3. Resistance reading of the motor with lead wires disconnected from the control box can determine if trouble is in motor or control box.

---

Pump is noisy and pump rate is low.

1. Impeller may be partially clogged with some foreign objects causing noise and overload on the motor.
2. Impeller may be rubbing on wear ring due to bent shaft or misalignment.
3. Pump may be operating too close to shut-off. Check head.

---

Grease and solids have accumulated around pump and will not pump out of basin.

1. Lower control which may be set too high.
  2. Run pump on manual operation for several minutes with a small amount of water running into basin to clean out solids and grease. This allows pump to break suction and surge, breaking up the solids. If level switch is set properly, this condition generally will not occur.
  3. Trash and grease may have accumulated around floats causing pump to operate erratically.
- 

**Myers®**