



**Detaljlista**

**Parts list**

**Ersatzteilliste**

**Liste des pièces de rechange**

**EEx: dII BT4**

**FM: Class I Div. 1 Grp. C and D**

**Class II Div. 1 Grp. E, F and G**

# 3126.290

890051/06

**Hur man läser dataskylten.  
Das bedeuten die Angaben auf  
dem Datenschild.**

**How to read the data plate.  
Comment lire la plaque  
signalétique.**

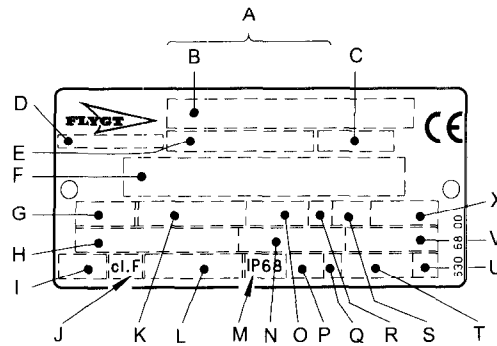

**Dataskylt inskription**

- A Seriennummer
- B Produktkod + Nummer
- C Kurv- / Propellerkod
- D Tillverkningsland
- E Produktnummer
- F Kompletterande uppgifter
- G Fastal; Strömart; Frekvens
- H Märkspänning
- I Termoskydd
- J Isolationsklass
- K Märkeffekt
- L Internationell standard
- M Skyddsklass
- N Märkström
- O Varvtal
- P Max. nedsänkingsdjup
- Q Rotationsriktning: L=vänster, R=höger
- R Driftklass
- S Driftfaktor
- T Produktvikt
- U Kodbokstav för låst rotor
- V Effektfaktor
- X Max. omgivningstemperatur

**Data plate interpretation**

- A Serial number
- B Product code + Number
- C Curve code / Propeller code
- D Country of origin
- E Product number
- F Additional information
- G Phase; Type of current; Frequency
- H Rated voltage
- I Thermal protection
- J Thermal class
- K Rated shaft power
- L International standard
- M Degree of protection
- N Rated current
- O Rated speed
- P Max. submergence
- Q Direction of rotation: L=left, R=right
- R Duty class
- S Duty factor
- T Product weight
- U Locked rotor code letter
- V Power factor
- X Max. ambient temperature

**Erläuterungen zum Datenschild**

- A Serien-Nr
- B Produktcode + Kennnummer
- C Kurven-Nr / Propellercode
- D Herstellungsland
- E Produkt-Nr
- F Kompletierende Angaben
- G Phasenzahl; Stromart; Frequenz
- H Nennspannung
- I Thermischer Schutz
- J Isolationsklasse
- K Nennwellenleistung
- L Internationale Norm
- M Schutzart
- N Nennstrom
- O Nenndrehzahl
- P Max. Eintauchtiefe
- Q Drehrichtung: L=links, R=rechts
- R Betriebsklasse
- S Relative Einschaltdauer
- T Produktgewicht
- U Kodebuchstabe für blockierten Läufer
- V Leistungsfaktor
- X Max. Umgebungstemperatur

**Légende de la plaque signalétique**

- A N° de série
- B Code de produit + N°
- C N° de courbe / Code d'hélice
- D Pays de fabrication
- E N° de produit
- F Informations complémentaires
- G Phases; Type de courant; Fréquence
- H Tension nominale
- I Protection thermique
- J Classe d'isolation
- K Puissance nominale sur l'arbre
- L Norme internationale
- M Classe de protection
- N Intensité nominale
- O Vitesse de rotation
- P Profondeur d'immersion maxi
- Q Sens de rotation: L=gauche, R=droite
- R Classe de fonctionnement
- S Facteur de marche
- T Poids de produit
- U Code alphabétique rotor verrouillé
- V Facteur de puissance
- X Température ambiante maxi

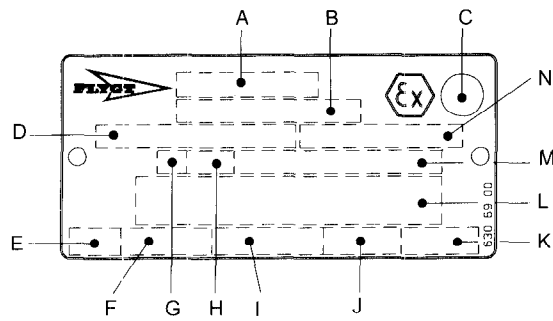

**Godkännandeskylt**

- A Godkännande
- B Provningsmynd. + Godkännandenummer
- C Godkännande för Klass I
- D Godkänd drivenhet
- E Fastbromsningstid
- F Startström / Märkström
- G Driftklass
- H Driftfaktor
- I Inmatad effekt
- J Varvtal
- K Kontrollant
- L Kompletterande uppgifter
- M Max. omgivningstemperatur
- N Serienummer

**Approval plate**

- A Approval
- B Approval authority + Approval Number
- C Approval for Class I
- D Approved drive unit
- E Stall time
- F Starting current / Rated current
- G Duty class
- H Duty factor
- I Input power
- J Rated speed
- K Controller
- L Additional information
- M Max. ambient temperature
- N Serial number

**Zulassungsschild**

- A Zulassung
- B Zulassungsstelle + Zulassungs-Nr
- C Zulassung für Klasse I
- D Zugelassener Antrieb
- E Abreißzeit
- F Anlaufstrom / Nennstrom
- G Betriebsklasse
- H Relative Einschaltdauer
- I Aufgenommene Leistung
- J Nenndrehzahl
- K Kontrollstelle
- L Kompletierende Angaben
- M Max. Umgebungstemperatur
- N Serienummer

**Plaque d'agrément**

- A Agrément
- B Organisme ayant délivré l'agrément + N° d'agrément
- C Agrément pour classe I
- D Agrément moteur
- E Temps de réaction des thermosondes
- F Intensité au démarrage / Intensité nominale
- G Classe de fonctionnement
- H Facteur de marche
- I Puissance absorbée
- J Vitesse de rotation
- K Contrôleur
- L Informations complémentaires
- M Température ambiante maxi
- N N° de série

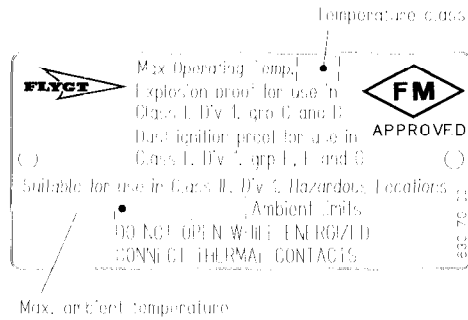

För att pumpen skall uppfylla bestämmelserna och myndigheters godkännande ska alltid Flygts originaldelar användas vid reparation.

Ingrepp på special-godkända pumpar får endast göras av Flygt eller av Flygt- auktoriserad verkstad/personal.

Reservdelar markerade med rött är underkastade måttkontroll.

Das Pumpe entspricht den Vorschriften und den behördlichen Genehmigungen nur unter Voraussetzung, daß bei Reparaturen ausschließlich Original-Flygt-Ersatzteile eingebaut werden.

Arbeiten an Pumpen mit Spezial-Zulassung dürfen nur von Flygt-Personal oder von durch Flygt autorisiertem Personal durchgeführt werden.

Mit rot gekennzeichnete Ersatzteile werden besonderen Maßhaltigkeitskontrollen unterzogen.

In order for the pump to fulfil requirements and obtain official approval, genuine Flygt parts must always be used for repairs.

Only Flygt or Flygt-authorized service personnel may undertake repair work on specially approved pumps.

Spare parts marked with red are subjected to dimensional accuracy inspection.

Pour que la pompe demeure conforme à la réglementation ainsi qu'à l'homologation accordée par les autorités compétentes, il est indispensable que seules des pièces Flygt d'origine soient utilisées lors des réparations.

Les interventions au niveau de pompes spécialement approuvés doivent être confiées uniquement à un personnel Flygt ou à un atelier agréé par Flygt.

Les pièces indiquées en rouge sont soumises à un contrôle de cotes.

Uppge pumpens produktnummer och tillverkningsnummer vid reservdelsbeställning.

Använd inte pos.nr utan detaljnr vid reservdelsbeställning och lagerhållning.

Tillverkarens garantibestämmelser gäller endast under förutsättning att Flygts originaldelar används samt att reparations- och servicearbetet utförs av en av Flygt auktoriserad verkstad.

Rätt till ändringar i utförande och specifikationer förbehålles.

Garantivillkoren förutsätter att pumpen används enligt instruktionen och i applikationer för vilka den är avsedd.

Bei Bestellung bitte die Produkt Nr. und die Fabrikations Nr. der Pumpe angeben. Die Pos.-Nummern sind nicht für die Lagerorganisation vorgesehen.

Die Garantiebestimmungen des Herstellers gelten nur unter der Voraussetzung, daß Original Flygt-Ersatzteile verwendet werden, und daß Reparatur- und Wartungsarbeiten von einer von Flygt autorisierten Werkstatt durchgeführt werden.

Änderungen in bezug auf Ausführung und Spezifikationen vorbehalten.

Die Garantiebedingungen voraussetzen daß die Pumpe laut der Instruktion und in Applikationen, zu welchen sie bestimmt ist, verwendet wird.

State product No. and serial No. of pump when ordering parts.

Do not use item Nos. when ordering spare parts or for stock records.

The provision of the manufacturer's guarantee applies only under the condition that genuine Flygt spare parts are used and that the repair and service work is carried out by a workshop authorized by Flygt.

The manufacturer reserves the right to alter specification and design.

The terms of the guarantee apply only providing the pump is used in accordance with the instructions and in applications for which it is intended.

Pour toute commande de pièces de rechange, prière d'indiquer le N° de produit et le N° de série de la pompe à laquelle ces pièces sont destinées.

Ne pas utiliser les numéros de repérage lors de la commande de pièces de rechange, ou sur les fiches de stocks. Utiliser les numéros de pièces.

La garantie du constructeur n'est valable que dans la mesure où sont exclusivement utilisées des pièces de rechange Flygt d'origine et où les réparations et interventions sont assurées par un atelier agréé par Flygt.

Nous nous réservons le droit de modifier l'exécution et les spécifications de nos produits.

La garantie n'est valable que dans la mesure où la pompe est utilisée conformément aux directives du constructeur et uniquement affectée aux usages auxquels elle est destinée.

<b>MT</b> = Medeltrycksutförande Mitteldruckausführung	Medium-head version (Curve No. 430—432) Modèle pression moyenne
<b>HT</b> = Högtrycksutförande Hochdruckausführung	High-head version (Curve No. 250) Modèle haute pression
<b>D</b> = Virvelhjulsutförande Wirbelradausführung	Vortex impeller version (Curve No. 481—483) Version roue vortex

<b>Innehåll</b>	<b>Contents</b>	
<b>Inhalt</b>	<b>Table des matières</b>	sid page Seite page
Pumpaggregat 3126.290 Pumpenaggregate 3126.290	Pump types 3126.290 Pompes 3126.290 .....	7
Pumpgropsdetaljer, CP 3126.290 Schachteinbauteile, CP 3126.290	Sump components, CP 3126.290 Equipement du puisard, CP 3126.290 .....	18
Pumplokalsdetaljer, CT 3126.290 Pumpenraum-Zubehör für CT 3126.290	Sump components, CT 3126.290 Equipement complémentaire pour pompe CT 3126.290 .....	20
Stativ och anslutning för CS 3126.290 Schlauchanschluß für CS 3126.290	Hose connection for CS 3126.290 Raccord de tuyau pour pompe CS 3126.290 . . . .	23
Sprängteckning med pos nr Explosionszeichnung mit Pos.-Nr.	Exploded view with item no Vue éclatée de la pompe avec N° de repérage . .	27

Pos nr Item No. Pos.-Nr. N° de repérage	Detalj nr Part No. Bestell-Nr. N° de pièce	Benämning Bezeichnung	Denomination Désignation	Antal Quantity Anzahl Nombre
1	80 76 73	Plattkil (8 x 7 x 45) Passfeder	Key Clavette	1
2	80 96 80	Pinnskruv (M12 x 55) Stiftschraube	Stud Goujon	6
		6-KANTSKRUV SECHSKANTSCHRAUBE	HEXAGON-HEADED SCREW VIS SIX-PANS	
3	81 41 04	(M8 x 20)		5
4	81 49 02	(M12 x 20)		2
5	81 73 86	Spårskruv (M8 x 12) Schlitzschraube	Slotted screw Vis à fente	2
6	82 21 73	Drivskruv (4 x 5) Kerbnagel	Drive screw Vis autotaraudeuse	14
10	82 23 35	6-kantmutter (M12) Sechskantmutter	Hexagonal nut Ecrou hexagonal	6
11	82 35 16	Bricka (8.4 x 16) Scheibe	Washer Rondelle	3
12	82 44 15	Bricka (40 x 50 x 2.5) Scheibe	Washer Rondelle	1
		FJÄDERBRICKA FEDERRING	SPRING WASHER RONDELLE GROWER	
13	82 48 92	(12.2)		10
14	82 48 88	(5.1)		2
15	82 48 90	(8.2)		6
16	82 59 06	Spårring (SgA 40) Nutting	Retaining ring Circlip	1
		O-RING O-RING	O-RING ANNEAU TORIQUE	
20	82 71 64	(215.99 x 3.53)		1
21	82 72 95	(19.2 x 3.0)		6
22	82 75 24	(194.3 x 5.7)		1
23	82 80 82	(104.5 x 3)		1
24	82 80 84	(74.2 x 5.7)		1
25	82 80 85	(159.3 x 5.7)		1
26	82 80 86	(239.3 x 5.7)		1
27	82 80 87	(249.3 x 5.7)		2
28	82 81 06	(259.3 x 5.7)		1
29	82 81 55	(100 x 5.7)		1

Pos nr Item No. Pos.-Nr. N° de repérage	Detalj nr Part No. Bestell-Nr. N° de pièce	Benämning Bezeichnung	Denomination Designation	Antal Quantity Anzahl Nombre
		INSEXSKRUV INNENSECHSKANT- SCHRAUBE	SOCKET HEAD SCREW VIS ALLEN	
34	82 00 34	(M 8 x 25)		6
35	83 03 47	(M 12 x 35)		10
36	83 15 71	Kullager (SKF6306 RS/C-3) Kugellager	Ball bearing Roulement à billes	1
37	83 37 17	Kullager (SKF 3308) Kugellager	Ball bearing Roulement à billes	1
38	83 42 28	Ändhylsa Endhülse	End sleeve Douille	6—12
39	83 42 36	Ändhylsa Endhülse	End sleeve Douille	2
40	83 44 23	Ändhylsa Endhülse	End sleeve Douille	0—1
41	84 42 54	Insexskruv (M12 x 40) Innensechskantschraube	Socket head screw Vis Allen	1
42	94 05 13	Isolerslang (0.05/0.1 m) Isolerschlauch	Insulation tube Gaine isolante	1
43	249 88 04	Skyddsledarskruv Erdungsschraube	Earthing screw Vis de terre	2
44	279 29 02	Skyddsledarplatta Erdungsplatte	Earthing plate Plaque de terre	1
45	515 67 01	INRE PLANTÄTNINGS- ENHET GLEITRINGDICHTUNG, INNER	MECHANICAL SEAL, INNER JOINT MECANIQUE, INT.	1
46	82 79 29	O-ring (54.5 x 3) O-Ring	O-ring Anneau torique	(1)
47*		Släpring Dichtungsring, stat.	Seal ring, stationary Anneau fixe	(1)
48*		Tättningsringenhet, rot. Dichtungsringeinheit, rot.	Seal ring unit, rot. Anneau tournant	(1)
49*		Klämhylsa Klemmhülse	Clamping sleeve Douille de serrage	(1)

\* Levereras ej separat  
Nicht separat geliefert

Not separately delivered  
N'est pas livré séparément



Pos nr Item No. Pos.-Nr. N° de repérage	Detalj nr Part No. Bestell-Nr. N° de pièce	Benämning Bezeichnung	Denomination Désignation	Antal Quantity Anzahl Nombre
50*		Tryckfjäder Druckfeder	Compression spring Ressort de compression	(1)
51*		Stoppring Hemring	Stop ring Anneau d'arrêt	(1)
52	301 19 09	Dragfjäder Hemmfeder	Stop spring Ressort d'arrêt	(1)

\* Levereras ej separat  
Nicht separat geliefert

Not separately delivered  
N'est pas livré séparément

INRE PLANTÄTNINGSENHET  
GLEITRINGDICHTUNG, INNER

MECHANICAL SEAL, INNER  
JOINT MECANIQUE, INT.

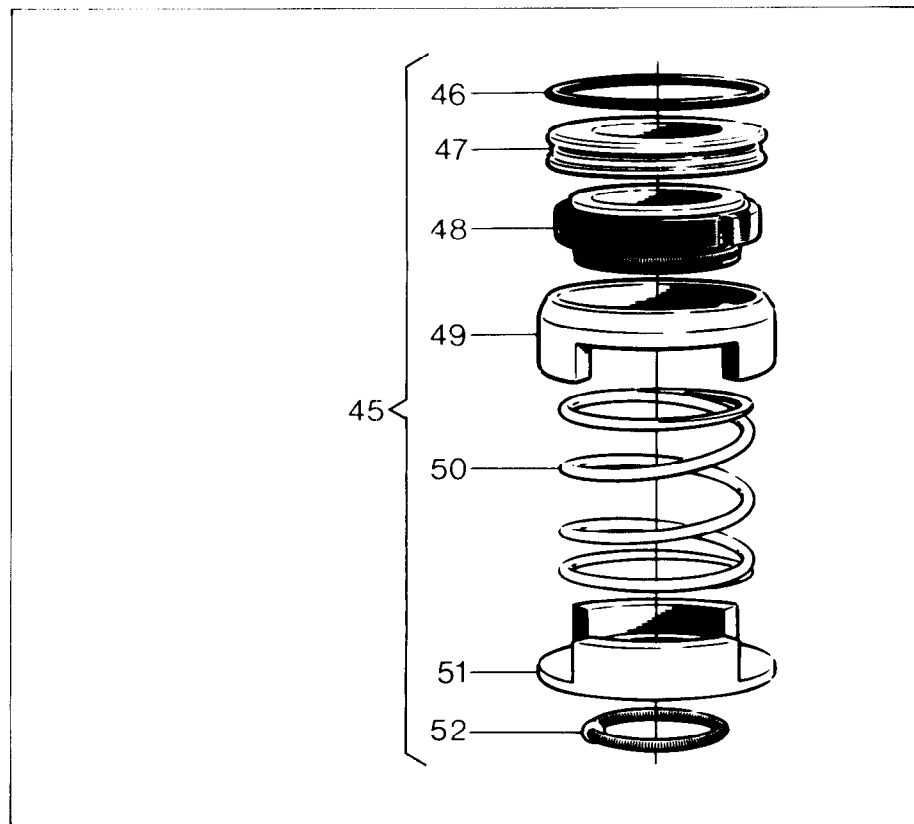

Pos nr Item No. Pos.-Nr. N° de repérage	Detalj nr Part No. Bestell-Nr. N° de pièce	Benämning Bezeichnung	Denomination Désignation	Antal Quantity Anzahl Nombre
56	308 86 02	Lyftbygel Tragbügel	Lifting handle Poignée	1
57	434 52 00	Lagerlock Lagerdeckel	Bearing cover Cache-roulement	1
58	434 51 00	Lagerhus, nedre Lagergehäuse, unteres	Bearing housing, lower Boîtier de roulement, inf.	1
59	338 13 06	Bricka Scheibe	Washer Rondelle	1
60	382 88 00	Propp Pfropf	Plug Bouchon	2
61	426 78 00	Skyddsledarbricka Erdungsscheibe	Earthing washer Rondelle de terre	2
62	426 80 00	Kopplingsplint Schaltbrett	Terminal board Plaque à bornes	1
63	428 10 04	Statorhus Statorgehäuse	Stator casing Logement de stator	1
64	428 11 02	Lagerhus, övre Lagergehäuse, oberes	Bearing housing, upper Boîtier de roulement, sup.	1
65	428 16 00	Oljehus Ölgehäuse	Oil housing Bac à huile	1
66	428 17 00	Kåpa Mantel	Outer casing Enveloppe extérieure	1
70				2
	428 18 00	Hylsa Hülse	Sleeve Manchon	
	429 29 01	Propp, Plug, Pfropf, Bouchon,	supersedes 428 18 00 when the pump is used with external cooling. remplace le 428 18 00 lorsque la pompe fonctionne avec un refroidissement externe.	
		ersätter 428 18 00 när pumpen körs med extern kylning. ersetzt 428 18 00 wenn die Pumpe mit Fremdkühlung betrieb wird.		
71	428 22 05	Inspektionsskruv Inspektionsschraube	Inspection screw Vis d'inspection	2
72	429 01 04	Införingslock Anschlussdosendeckel	Junction box cover Couvercle	1

Pos nr Item No. Pos.-Nr. N° de repérage	Detalj nr Part No. Bestell-Nr. N° de pièce	Benämning Bezeichnung	Denomination Désignation	Antal Quantity Anzahl Nombre
75	429 21 04	YTTRE PLANTÄTNINGS- ENHET GLEITRINGDICHTUNG, ÄUSSER	MECHANICAL SEAL, OUTER JOINT MECANIQUE, EXT.	1
76	82 81 00	O-ring (39.2 × 3.0) O-Ring	O-ring Anneau torique	(1)
77	82 79 13	O-ring (45.0 × 5.0) O-Ring	O-ring Anneau torique	(1)
78	82 79 29	O-ring (53.0 × 4.0) O-Ring	O-ring Anneau torique	(1)
79	82 80 96	O-ring (34.2 × 3.0) O-Ring	O-ring Anneau torique	(1)
80*		Hylsa Hülse	Sleeve Douille	(1)
81*		Tryckfjäder Druckfeder	Compression spring Ressort de compression	(1)
82*		Släpring Dichtungsring, stationärer	Seal ring, stationary Anneau fixe	(1)
83*		Ändbricka Scheibe	End washer Rondelle	(1)
84*		Tättningsringhållare Dichtungsringhalter	Seal ring holder Support à joint	(1)
85*		Tättningsring, roterande Dichtungsring, rot.	Seal ring, rot. Anneau tournant	(1)
86	429 25 01	Rör Rohr	Pipe Tuyau	1
87		SKYLT SCHILD	PLATE PLAQUE	
	630 68 00	Data plate		1
	274 52 00	Export plate		1
	441 56 01	Certificate plate		1
90		SLITRING VERSCHLEISSRING	WEAR RING ANNEAU D'USURE	1
	309 29 02	For MT		
	309 34 02	For HT		

\* Levereras ej separat      Not separately delivered  
Nicht separat geliefert      N'est pas livré séparément

YTTRE PLANTÄTNINGSENHET  
GLEITRINGDICHTUNG, ÄUSSER

MECHANICAL SEAL, OUTER  
JOINT MECANIQUE, EXT.

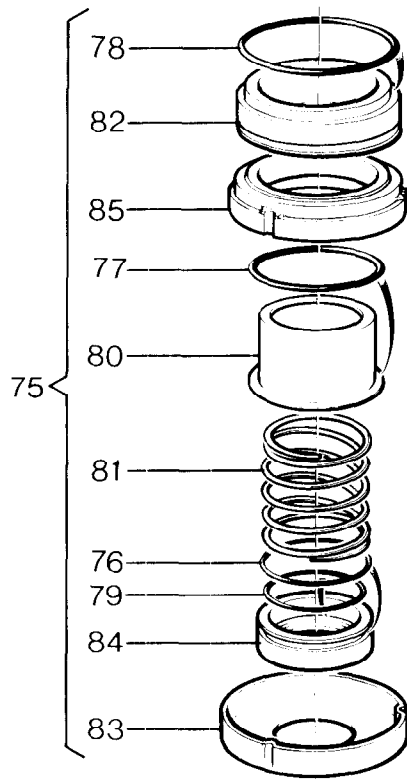

Pos nr Item No. Pos.-Nr. N° de repérage	Detalj nr Part No. Bestell-Nr. N° de pièce	Benämning Bezeichnung	Denomination Désignation	Antal Quantity Anzahl Nombre
---	---	--------------------------	-----------------------------	---------------------------------------

91		PUMPHUS PUMPENGEHÄUSE	PUMP CASING VOLUTE	1
----	--	--------------------------	-----------------------	---

**MT DN 100**

433 71 00



433 71 01



SMS 342, DIN 2533  
BS 4622:1970 Table 11

433 71 02



1882 Standard

433 71 05



ANSI B 16.1:1967 Table 5 (USA)

**HT DN 100**

457 84 00



457 84 01



SMS 342, DIN 2533  
BS 4622:1970 Table 11

457 84 02



1882 Standard





457 84 05



ANSI B 16.1:1967 Table 5 (USA)

Pos nr Item No. Pos.-Nr. N° de repérage	Detalj nr Part No. Bestell-Nr. N° de pièce	Benämning Bezeichnung	Denomination Désignation	Antal Quantity Anzahl Nombre
---	---	--------------------------	-----------------------------	---------------------------------------

**HT DN 80**

433 70 00				
433 70 01		SMS 342, DIN 2533 1882 Standard		
433 70 05		ANSI B 16.1:1967 Table 5 (USA)		
433 70 07		BS 4622:1970 Table 11		

92	STATOR STATOR	STATOR STATOR	1
----	------------------	------------------	---

50 Hz	60 Hz
5.3 kW, 1440 r/min	6.3 kW, (8.5 hp), 1720 r/min

426 63 02	400/230 V	—
426 63 12	—	440—460/220—230 V
426 63 28	190—200 V Δ	200—220 V Δ
426 63 30	—	380 V Δ
426 63 32	350/200—208 V	400/230—240 V
426 63 34	380/220 V	440/260 V
426 63 35	346—350 V Δ	—
426 63 38	660/380 V	440—460 V Δ
426 63 40	400 V Δ	400 V Δ
426 63 44	400—440 V Δ	—
426 63 52	500—550 V Δ	575 V Δ
426 63 58	660 V Δ	—
426 63 01	690/400 V	—
426 63 03	690 V Δ	—

50 Hz	60 Hz
6.7 kW, 1430 r/min	8.3 kW, (11 hp), 1730 r/min

309 44 12	—	440—460/220—230 V
309 44 28	190—220 V Δ	380/200—220 V
309 44 30	—	380 V Δ
309 44 32	350/200—208 V	400/230—240 V
309 44 34	380—400/220—230 V	440/260 V
309 44 35	346—350 V Δ	—
309 44 38	660—690/380—400 V	440—460 V Δ
309 44 40	400 V Δ	400 V Δ
309 44 44	400—440 V Δ	—
309 44 52	500—550 V Δ	575 V Δ
309 44 58	660—690 V Δ	—

Pos nr Item No. Pos.-Nr. N° de repérage	Detalj nr Part No. Bestell-Nr. N° de pièce	Benämning Bezeichnung	Denomination Désignation	Antal Quantity Anzahl Nombre
---	---	--------------------------	-----------------------------	---------------------------------------

		50 Hz 8.0 kW, 2870 r/min	60 Hz 9.0 kW, (12 hp), 3450 r/min	
	309 49 01	400/230 V	—	
	309 49 12	—	440—460/220—230 V	
	309 49 28	190—200 V Δ	200—220 V Δ	
	309 49 30	—	380 V Δ	
	309 49 32	350/200—208 V	400/230—240 V	
	309 49 34	380/220 V	440/260 V	
	309 49 38	660/380 V	440—460 V Δ	
	309 49 40	400 V Δ	400 V Δ	
	309 49 44	400—440 V Δ	—	
	309 49 52	500—550 V Δ	575 V Δ	
	309 49 58	660 V Δ	—	
	309 49 02	690/400 V	—	
	309 49 03	690 V Δ	—	

93	438 09 00	Skyddsskiva, endast för stator 426 63 xx Schutzscheibe, nur für Stator 426 63 xx	Protection disc, for stator 426 63 xx only Disque de protection, seulement pour stator 426 63 xx	
----	-----------	---	---	--

94	439 73 01	Rör Rohr	Pipe Tuyau	1
----	-----------	-------------	---------------	---

95		AXEL-ROTORENHET ROTOREINHEIT	SHAFT-ROTOR UNIT ARBRE-RÖTOR COMPLET	1	
	308 92 05	För stator For stator Für Stator Pour stator	} 309 44 xx		
	308 92 06	För stator For stator Für Stator Pour stator		} 426 63 xx	
	309 54 03	För stator For stator Für Stator Pour stator			} 309 49 xx

96		PUMPHJUL, Kurva nr ... LAUFRAD, Kurve Nr. ...	IMPELLER, Curve No. ... ROUE, Courbe N° ...	1
----	--	--	--	---

429 04 00	MT430, 50 Hz
429 05 00	MT432, 50—60 Hz
439 22 09	MT476, 50—60 Hz
439 22 13	MT479, 50—60 Hz
429 06 00	HT250, 50 Hz
436 83 04	HT252, 50 Hz
436 83 00	HT467, 50—60 Hz
436 83 03	HT461, 50—60 Hz
436 83 04	HT462, 50—60 Hz

Pos nr Item No. Pos.-Nr. N° de repérage	Detalj nr Part No. Bestell-Nr. N° de pièce	Benämning Bezeichnung	Denomination Désignation	Antal Quantity Anzahl Nombre
	439 22 00	D481, 50 Hz		
	439 22 07	D475, 50 Hz		
	439 22 11	D477, 50 Hz		
	439 22 13	D478, 50—60 Hz		
	439 22 20	D287, 50—60 Hz		
97	436 84 00	Suglock Pumpengehäuseboden	Pump casing bottom Fond de volute	
100		INFÖRINGSENHET LEITUNGSEIN- FÜHRUNGSEINHEIT	CABLE ENTRY UNIT ENTRÉE DE CABLE COMPLÈTE	1
	439 25 00	(14)—24 mm (0.55"—0.94")		
	439 25 01	(24)—32 mm (0.94"—1.26")		
101	81 73 63	Spårskruv (M5 x 30) Schlitzschraube	Slotted screw Vis à fente	(2)
102	82 23 30	6-kantmutter (M5) Sechskantmutter	Hexagonal nut Ecrou hexagonal	(2)
103*		Klammer Klammer	Clamp Crampon	(2)
104*		Införingsfläns Leitungseinführungs- flansch	Cable entry flange Bride d'entrée	(1)
105		SPEC. BRICKA SCHEIBE	WASHER RONDELLE	2
	82 42 64	(18)—20 mm (0.71"—0.79")		
	82 42 65	(20)—22 mm (0.79"—0.87")		
	82 42 66	(22)—24 mm (0.87"—0.94")		
	82 42 67	(24)—26 mm (0.94"—1.02")		
	82 42 68	(26)—28 mm (1.02"—1.10")		
	82 42 69	(28)—30 mm (1.10"—1.18")		
	82 42 71	(30)—32 mm (1.18"—1.26")		

\* Levereras ej separat  
Nicht separat geliefert

Not separately delivered  
N'est pas livré séparément







Pos nr Item No. Pos.-Nr. N° de repérage	Detail nr Part No. Bestell-Nr. N° de pièce	Benämning Bezeichnung	Denomination Désignation	Antal Quantity Anzahl Nombre
106		TÄTNINGSHYLSA DICHTUNGSHÜLSE	SEAL SLEEVE MANCHON	1
	84 43 92	(18)—20 mm (0.71"—0.79")		
	84 43 93	(20)—22 mm (0.79"—0.87")		
	84 43 94	(22)—24 mm (0.87"—0.94")		
	84 43 95	(24)—26 mm (0.94"—1.02")		
	84 43 96	(26)—28 mm (1.02"—1.10")		
	84 43 97	(28)—30 mm (1.10"—1.18")		
	84 43 98	(30)—32 mm (1.18"—1.26")		
107		Införingsfläns för motor- sladd med skyddsslang Einführungsflansch für Motorleitung mit Schutz- schlauch	Entry flange for motor cable with protection hose Bride d'entrée pour câble avec manchon de protection	1
	429 23 00	(14)—24 mm (0.55"—0.94")		
	429 23 01	(24)—32 mm (0.94"—1.26")		
108	82 81 03	O-ring (49.5 x 3.0) O-Ring	O-ring Anneau torique	1
109		Skyddsslang för motorsladd Schutzschlauch für Motorleitung	Protection hose for motor cable Manchon de protection pour câble	1
	400 33 00	(14)—24 mm (0.55"—0.94")		
	429 24 00	(24)—32 mm (0.94"—1.26")		
110		MOTORSLADD MOTORLEITUNG	MOTOR CABLE CABLE	
	94 11 59	NSSHÖU-J 7 x 2.5 mm <sup>2</sup>		
	94 11 60	NSSHÖU-J 12 x 2.5 mm <sup>2</sup>		
	94 18 98	AWG # 8/3-2-1		
	94 21 22	AWG # 8/3-2-1 GC		
	94 21 09	AWG # 6/3-2-1 GC		
	94 21 06	AWG # 10/3-2-1 GC		
	94 20 59	Subcab 4G 2.5 + 2 x 1.5 (Ø 17—18 mm)		
	94 20 82	Subcab 7G 2.5 + 2 x 1.5 (Ø 20—23 mm)		

**Pumpgropsdetaljer,  
CP 3126.290  
Schachteinbauteile,  
CP 3126.290**





**Sump components,  
CP 3126.290  
Equipement du puisard  
CP 3126.290**

Pos nr Item No. Pos.-Nr. N° de repérage	Detalj nr Part No. Bestell-Nr. N° de pièce	Benämning Bezeichnung	Denomination Désignation	Antal Quantity Anzahl Nombre
120	81 49 09	6-kantskruv (M12 × 45) Sechskantschraube	Hexagon-headed screw Vis six-pans	4
121	429 07 00	Styrklo Gleitklaue	Sliding bracket Glissière	1
122	255 47 02	Mellanlägg Gummihülse	Rubber tube Manchon	2
123		KOPPLINGSFOT KUPPLUNGSFUSS	DISCHARGE CONNECTION PIED D'ASSISE	1

MT DN 100	
429 08 00	
429 08 01	 SMS 342, DIN 2533 BS 4622:1970 Table 11
429 08 02	 1882 Standard
429 08 05	 ANSI B 16.1:1967 Table 5 (USA)

Pos nr Item No. Pos.-Nr. N° de repérage	Detalj nr Part No. Bestell-Nr. N° de pièce	Benämning Bezeichnung	Denomination Désignation	Antal Quantity Anzahl Nombre
---	---	--------------------------	-----------------------------	---------------------------------------

HT DN 80

429 09 00				
429 09 01		SMS 342, DIN 2533 1882 Standard		
429 09 05		ANSI B 16.1:1967 Table 5 (USA)		
429 09 07		BS 4622:1970 Table 11		

CP 3126.290

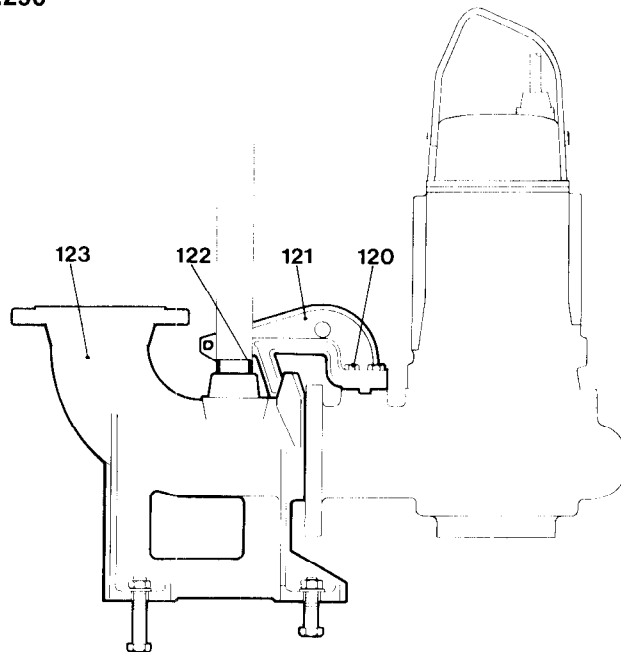

**Pumplokalsdetaljer,  
CT 3126.290  
Pumpenraum-Zubehör  
für CT 3126.290**

**Sump components,  
CT 3126.290  
Équipement complémentaire  
pour pompe CT 3126.290**

Pos nr Item No. Pos.-Nr. N° de repérage	Detalj nr Part No. Bestell-Nr. N° de pièce	Benämning Bezeichnung	Denomination Désignation	Antal Quantity Anzahl Nombre
135		BRICKA SCHEIBE	WASHER RONDELLE	4
	82 35 23	For MT (17 x 30)		
	82 35 20	For HT (13 x 24)		
136		O-RING O-RING	O-RING ANNEAU TORIQUE	1
	82 81 02	For MT (164.3 x 5.7)		
	82 72 90	For HT (124.3 x 5.7)		
137		6-KANTSKRUV SECHSKANTSCHRAUBE	HEXAGON-HEAD SCREW VIS SIX-PANS	
	84 34 03	For MT (M16 x 40)		
	81 41 56	For HT (M12 x 35)		

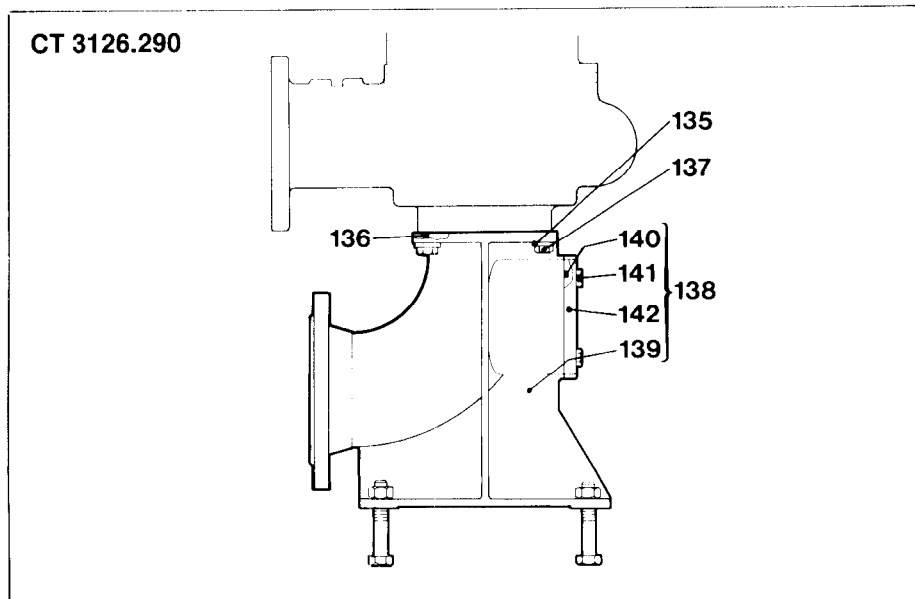

Pos nr Item No. Pos.-Nr. N° de repérage	Detalj nr Part No. Bestell-Nr. N° de pièce	Benämning Bezeichnung	Denomination Désignation	Antal Quantity Anzahl Nombre
---	---	--------------------------	-----------------------------	---------------------------------------

138		SUGRÖRSENHET SAUGROHREINHEIT	SUCTION PIPE UNIT CONDUITE D'ASPIRATION COMPLET	1
-----	--	---------------------------------	---	---

139*		SUGRÖR FÖR SAUGROR FÜR	SUCTION PIPE FOR CONDUITE D'ASPIRATION POUR	MT DN 150
------	--	---------------------------	---	-----------

431 75 00



431 75 02



1882 Standard

431 75 06



SMS 342, DIN 2533  
BS 4622:1970 Table 11  
ANSI B 16.1:1967 Table 5 (USA)

139*		SUGRÖR FÖR SAUGROHR FÜR	SUCTION PIPE FOR CONDUITE D'ASPIRATION POUR	HT DN 100
------	--	----------------------------	---	-----------

431 74 00



431 74 01



SMS 342, DIN 2533  
BS 4622:1970 Table 11

431 74 02



1882 Standard

431 74 05



ANSI B 16.1:1967 Table 5 (USA)

\* Levereras ej separat  
Nicht separat geliefert

Not separately delivered  
N'est pas livré séparément

Pos nr Item No. Pos.-Nr. N° de repérage	Detalj nr Part No. Bestell-Nr. N° de pièce	Benämning Bezeichnung	Denomination Désignation	Antal Quantity Anzahl Nombre
140		O-RING O-RING	O-RING ANNEAU TORIQUE	1
	82 80 92	For MT (144.5 x 3)		
	82 75 14	For HT (94.5 x 3)		
141		6-KANTSKRUV SECHSKANTSCHRAUBE	HEXAGON-HEADED SCREW VIS SIX-PANS	4
	84 34 03	For MT (M16 x 40)		
	81 41 55	For HT (M12 x 30)		
142		RENSLUCKA REINIGUNGSDECKEL	CLEANING DOOR REGARD DE NETTOYAGE	
	429 15 00	For MT		
	429 14 00	For HT		
	80 32 39	O-ring kit		

**Stativ och anslutning för  
CS 3126.290  
Schlauchanschluß für  
CS 3126.290**

**Hose connection for  
CS 3126.290  
Raccord de tuyau pour pompe  
CS 3126.290**

Pos nr Item No. Pos.-Nr. N° de repérage	Detalj nr Part No. Bestell-Nr. N° de pièce	Benämning Bezeichnung	Denomination Désignation	Antal Quantity Anzahl Nombre
150	82 81 13	O-ring (109.1 x 5.7) O-Ring	O-ring Anneau torique	1
151	310 12 02	Stativ Ständer	Stand Bâti	2
<b>MT diam. 100 mm (4")</b>				
152	81 41 81	6-kantskruv (M16 x 40) Sechskantschraube	Hexagon-head screw Vis six-pans	4
153	81 49 58	6-kantskruv (M20 x 60) Sechskantschraube	Hexagon-head screw Vis six-pans	4
154	82 23 38	6-kantmutter (M20) Sechskantmutter	Hexagonal nut Ecrou hexagonal	4
155	82 35 78	Bricka (17 x 30) Scheibe	Washer Rondelle	4
156	82 35 79	Bricka (21 x 36) Scheibe	Washer Rondelle	4
157	429 13 00	Slanganslutning Schlauchstutzen	Hose connection Raccord de tuyau	1
<b>HT diam. 75 mm (3")</b>				
152	81 49 07	6-kantskruv (M12 x 35) Sechskantschraube	Hexagon-head screw Vis six-pans	4
153	81 49 36	6-kantskruv (M16 x 65) Sechskantschraube	Hexagon-head screw Vis six-pans	4
154	82 23 37	6-kantmutter (M16) Sechskantmutter	Hexagonal nut Ecrou hexagonal	4
155	82 35 77	Bricka (13 x 24) Scheibe	Washer Rondelle	4
156	82 35 78	Bricka (17 x 30) Scheibe	Washer Rondelle	4
157	429 12 00	Slanganslutning Schlauchstutzen	Hose connection Raccord de tuyau	1

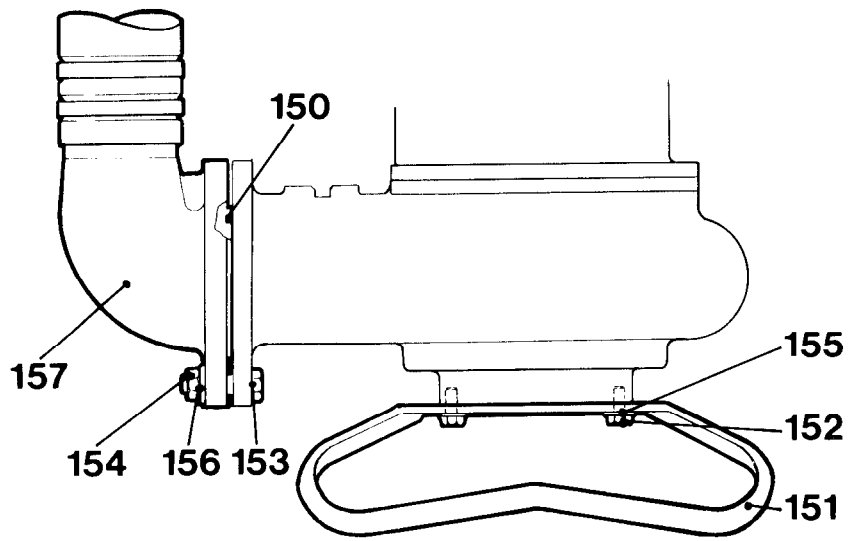





# NOTES

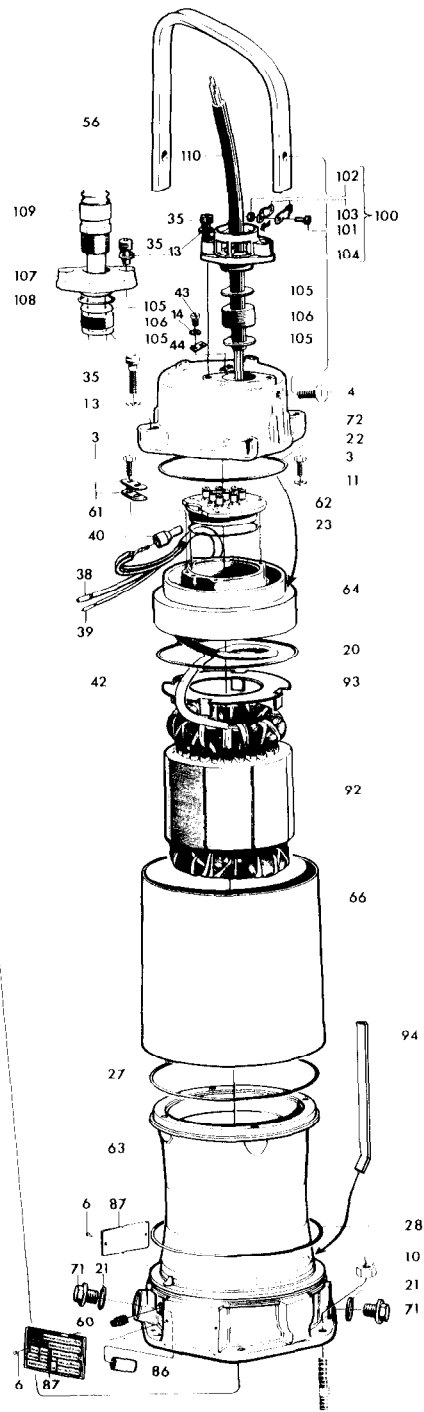
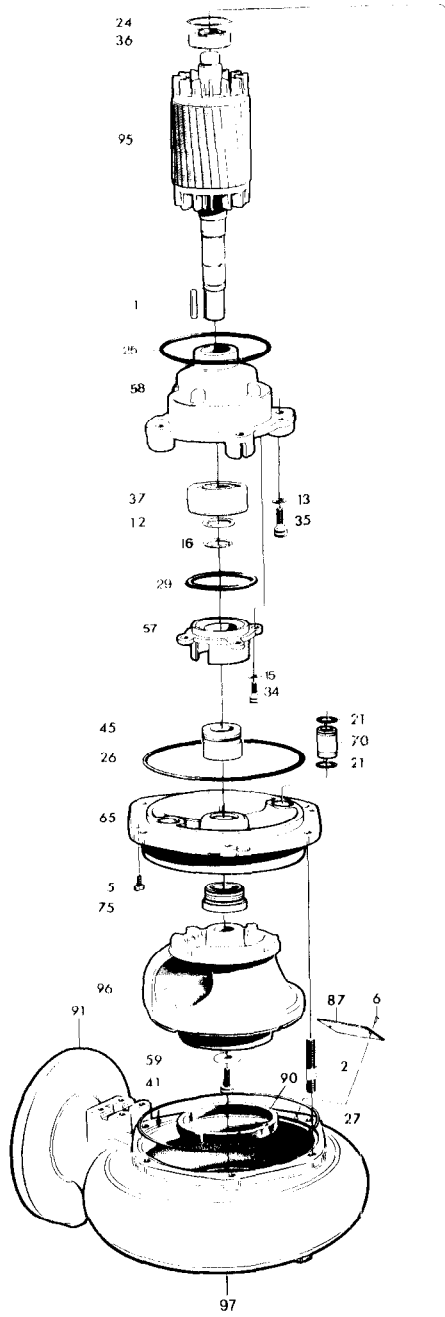



---

3126.290.07.06. Int. 1M. 08.99 © ITT FLYGT AB

890051

Printed in Sweden **KT** 990709