

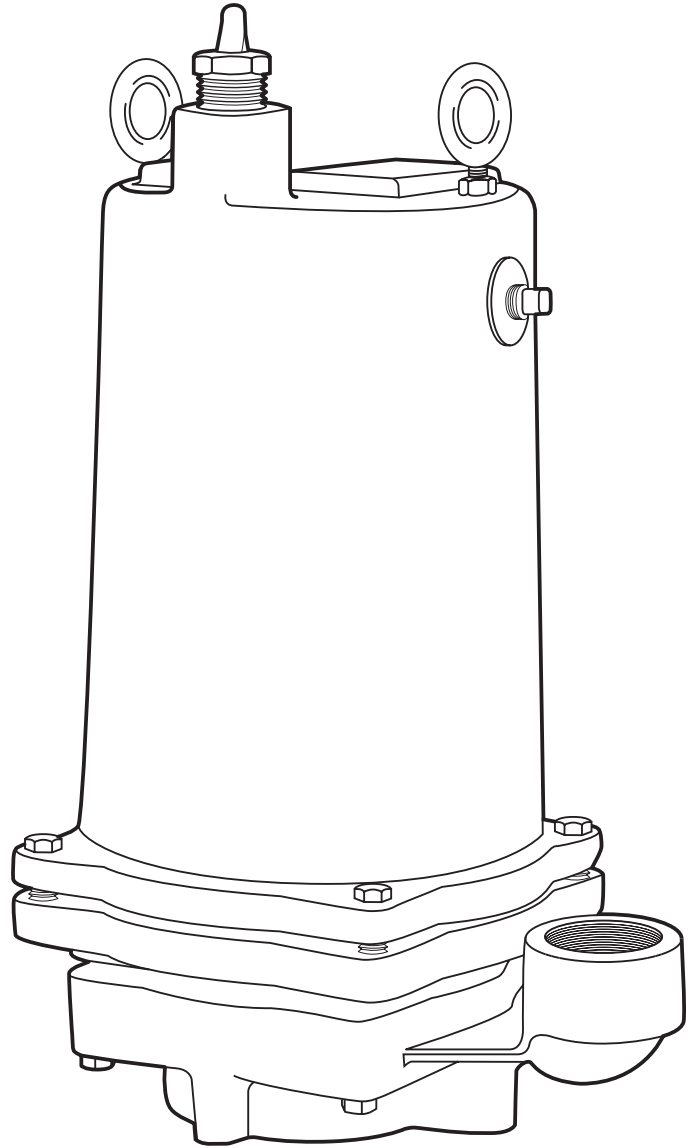

**HYDROMATIC®**



# MODEL HPGR200 SUBMERSIBLE GRINDER PUMP

## INSTALLATION AND SERVICE MANUAL



NOTE! To the installer: Please make sure you provide this manual to the owner of the equipment or to the responsible party who maintains the system.

# General Information

## Attention:

This manual contains important information for the safe use of this product. **DO NOT THROW AWAY OR LOSE THIS**

**MANUAL.** Reasonable care and safe methods should be practiced. Check local codes and requirements before installation.

**WARNING: Before handling these pumps and controls, always disconnect the power first. Do not smoke or use sparkable electrical devices or flames in a septic (gaseous) or possible septic sump.**

## Pump Cautions and Warnings

**DANGER: Risk of Electrical Shock or Electrocutation.** May result in serious injury or death or fire hazard. Installer must disconnect all electrical sources prior to installation, handling or servicing. Only qualified personnel may install this system. NFPA 70: National Electric Code® (NEC) or local codes must be followed. System must be properly grounded according to NEC. Do not lift pump by power cord.

**DANGER: Biohazard Risk.** Once wastewater source has been connected to system, biohazard risk exists. Installer(s) and/or service personnel must use proper personal protective equipment and follow handling procedures per OSHA 29 CFR 1910.1030 when handling equipment after wastewater source has been connected to system.

**DANGER: Risk of Asphyxiation.** Installer(s) and/or service personnel must use proper personal protective equipment and follow OSHA 29 CFR 1910.146 or OSHA 29 CFR 1926. Pump may be installed in a location classified as a confined space.

**DANGER: Risk of Fire or Explosion.** Do not smoke or use open flames in or around this system. HPGR200 systems are not intended for use in hazardous locations per NFPA 70: National Electric Code. Do not pump flammable liquids.

**DANGER: Cutting Risk.** Risk of serious cutting or amputation exists. Disconnect all power sources prior to servicing pump or grinding mechanism. Pump may start without warning. Grinding mechanism is extremely sharp. Use caution when handling grinder mechanism.

**DO NOT** modify the cord strain relief. When wiring to a system control, connect the pump ground lead to the system ground.

**DO NOT** run the pump dry. Dry running can overheat the pump (causing burns to anyone handling it) and will void the warranty.

The pump normally runs hot. To avoid burns, allow it to cool for 30 minutes after shutdown before handling it.

Submersible grinder pumps are not approved for use in swimming pools, recreational water installations, decorative fountains or any installation where human contact with the pumped fluid is common. This specialized pump is designed to incorporate a grinding mechanism to remove wastewater particulate and pump the

resulting slurry from a residential structure to a collection system.

Examine all lifting devices, rope or chain for damage before and after each lift.

DO NOT exceed manufacturers recommendation for maximum performance, as this could cause the motor to overheat.

Secure the pump in its operating position so it cannot tip over, fall or slide.

DO NOT pump without safety devices in place.

Basin must be vented in accordance with the local plumbing codes.

## CALIFORNIA PROPOSITION 65 WARNING:

**⚠ WARNING** This product and related accessories contain chemicals known to the State of California to cause cancer, birth defects or other reproductive harm.

## Pump Installation

### Installing Pump in Sump:

Before installing pump in sump, lay it on its side and rotate impeller. The impeller should turn freely. Do not connect the power until after this test.

Clean all trash and sticks from sump and connect pump to piping. A check valve must be installed on each pump.

### Location:

If pumps are installed in an existing basin or concrete sump, the piping can either be connected permanently or rails and brackets can be furnished for mounting to walls of basin. In either case, be sure that a Hydromatic® check valve is used and that the pumps are submerged in a vertical position. The complete factory-built packaged system is recommended.

### Making Electrical Connections:

All wires should be checked for shorts to ground with an ohmmeter or Megger after the connections are made.

## Pump Operation

To reduce the risk of electrical shock, install only on a GFCI protected circuit. See pump nameplate for electrical ratings.

To start the pump, perform the following steps in order:

1. When grinder pump is single phase, no rotation check is necessary. Correct rotation is counter-clockwise.
2. Run water into sump until motor is covered.
3. Open gate valve in discharge line.
4. Turn pump on. If pump runs and sump liquid does not pump down, stop pump and close discharge gate valve. Lift pump until sealing flange is open to vent off trapped air. Lower pump, open discharge valve, and start the pump again.

**CAUTION: Positive displacement pump is designed to operate at minimum 5 GPM capacity. Running pump at shut-off condition**

**or with gate valve closed can result in damage to the pumping stator boot and rotor.**

5. Level control should be set so that pump turns off when level is about 2 inches above inlet of pump suction and turns on when level is about 2 inches above motor.
6. If problems occur, check power source. Make sure a separate supply line is available. Verify voltage supply.
7. Check resistance of windings. If not within guidelines, return pump to authorized factory service center.

As the motors are oil filled, no lubrication or other maintenance is required. Pump should be checked every quarter for corrosion and wear.

## Pump Servicing

### Replacing Grinder Parts:

Close gate valve at pump discharge and turn off circuit breaker.

Remove pump from sump, unscrew screws and remove cutter ring retainer.

Unscrew hex head cap screws and remove volute case.

Radial cutter and axial cutter are now exposed.

If necessary to replace cutters, remove screw, washer and radial cutter from shaft. Tap radial cutter if necessary to loosen. Axial cutter lifts off impeller and is held from rotation by pin. Unscrew impeller from shaft in same manner.

Clean all parts thoroughly before proceeding with assembly. Replace case, cutter ring and cutter ring retainer.

Plug pump into power and operate for a few seconds only to ensure parts are not rubbing.

### Replacing Seal:

Drain the oil from the pump and remove the volute and cutters.

Remove the impeller and seal rotating elements by sliding the spring bellows off the shaft.

Break the old stationary portion of the seal to allow for removal.

Take the stationary portion of the new seal and lube the rubber material with Hydromatic oil. Press the stationary portion of the new seal into the seal/bearing plate.

**CAUTION: Do not reuse old seal parts. Replace all parts with new.**

Lube the rubber material on the carbon seal assembly and press it on the shaft. Place the spring bellows on the shaft as removed.

Using a pressure gauge with a fill stem, pressurize the motor housing no more than 7 psig with dried air and check for leaks for several minutes.

**NOTE: It is normal to observe some air bubbles in the seal area initially as the seal seats. If bubbles do not stop within a few seconds, the seal is either not properly installed or is damaged.**

Reassemble the cutter and volute.

Refill motor housing with Hydromatic oil. Fill the motor housing so that the tops of the motor windings have been covered, but leave an air gap to allow for expansion of the oil.

# HPGR200 Parts List

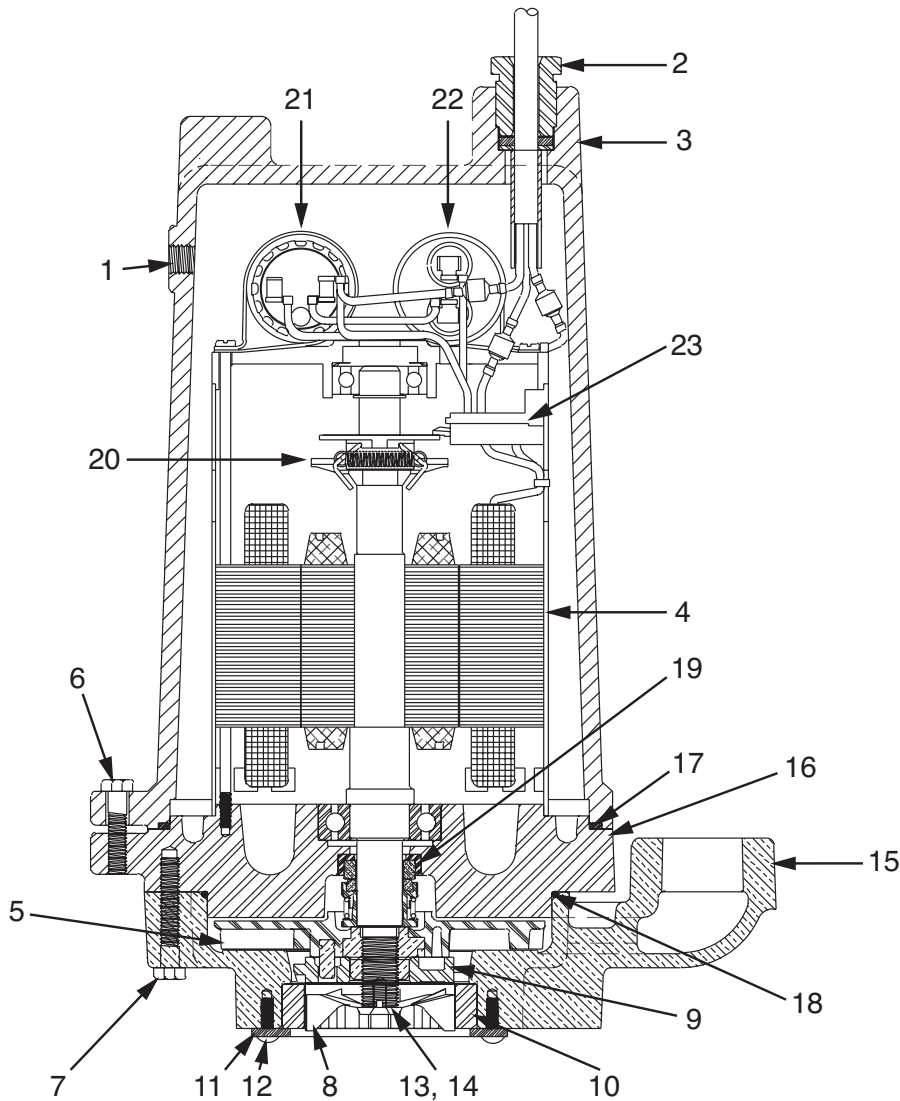

Ref. No.	Part No.	Part Description	Qty.
1	05022A092	Oil Fill Plug	1
2	25338B001	Power Cord	1
3	145890022	Motor Housing	1
4	145700001	Motor (Marathon®)	1
5	070330203	Impeller	1
6	19100A012	Screw	4
7	001010111	Screw	4
8	054050012	Radial Cutter	1
9	055060022	Axial Cutter	1
10	055050002	Stationary Cutter	1
11	077630001	Cutter Retainer	1
12	000190011	Screw	3
13	055700051	Impeller Washer	1
14	148850001	Impeller Screw	1
15	109570002	Volute	1
16	145690002	Bearing Housing	1
17	05014A181	O-ring	1
18	008340231	O-ring	1
19	145730001	Shaft Seal	1
20	152249001	Mechanical Switch (AO Smith™)	1
	26466C003	Mechanical Switch (Marathon)	1
21	12141A018	Start Cap (AO Smith)	1
	12141A000	Start Cap (Marathon)	1
22	23838A010	Run Cap (AO Smith)	1
	145700041	Run Cap (Marathon)	1
23	152249011	Stationary Switch (AO Smith)	1
	26466C004A	Stationary Switch (Marathon)	1
NOT SHOWN	21929A002	Eye Bolt	2
	010320021	Hex Nut	2
	145950201	For Automatic Operation Wide Angle Switch 20'	

## Troubleshooting

Below is a list of troubles and their probable causes:

### No liquid delivered

1. Pump airbound
2. Discharge head too high
3. Pump or piping plugged
4. Speed too low

### Insufficient liquid delivered

1. Discharge head too high
2. Impeller or cutters partially plugged or damaged
3. Incorrect impeller diameter
4. Speed too low

### Insufficient discharge pressure

1. Air or gases in liquid
2. Impeller damaged
3. Incorrect impeller diameter
4. Speed too low

### Pump overloads motor

1. Specific gravity or viscosity of liquid too high
2. Speed too high
3. Head lower than rating, pumping too much liquid
4. Pump clogged
5. Defective bearings
6. Defective impeller

### Pump is noisy

1. Defective bearings
2. No axial clearance between impeller and volute
3. No diametral clearance between radial cutter and cutter ring

## STANDARD LIMITED WARRANTY

Pentair Hydromatic® warrants its products against defects in material and workmanship for a period of 12 months from the date of shipment from Pentair Hydromatic or 18 months from the manufacturing date, whichever occurs first – provided that such products are used in compliance with the requirements of the Pentair Hydromatic catalog and technical manuals for use in pumping raw sewage, municipal wastewater or similar, abrasive-free, noncorrosive liquids.

During the warranty period and subject to the conditions set forth, Pentair Hydromatic, at its discretion, will repair or replace to the original user, the parts that prove defective in materials and workmanship. Pentair Hydromatic reserves the right to change or improve its products or any portions thereof without being obligated to provide such a change or improvement for prior sold and/or shipped units.

Start-up reports and electrical schematics may be required to support warranty claims. Submit at the time of start up through the Pentair Hydromatic website: <http://forms.pentairliterature.com/startupform/startupform.asp?type=h>. Warranty is effective only if Pentair Hydromatic authorized control panels are used. All seal fail and heat sensing devices must be hooked up, functional and monitored or this warranty will be void. Pentair Hydromatic will cover only the lower seal and labor thereof for all dual seal pumps. Under no circumstance will Pentair Hydromatic be responsible for the cost of field labor, travel expenses, rented equipment, removal/reinstallation costs or freight expenses to and from the factory or an authorized Pentair Hydromatic service facility.

This limited warranty will not apply: (a) to defects or malfunctions resulting from failure to properly install, operate or maintain the unit in accordance with the printed instructions provided; (b) to failures resulting from abuse, accident or negligence; (c) to normal maintenance services and parts used in connection with such service; (d) to units that are not installed in accordance with applicable local codes, ordinances and good trade practices; (e) if the unit is moved from its original installation location; (f) if unit is used for purposes other than for what it is designed and manufactured; (g) to any unit that has been repaired or altered by anyone other than Pentair Hydromatic or an authorized Pentair Hydromatic service provider; (h) to any unit that has been repaired using non factory specified/OEM parts.

**Warranty Exclusions:** PENTAIR HYDROMATIC MAKES NO EXPRESS OR IMPLIED WARRANTIES THAT EXTEND BEYOND THE DESCRIPTION ON THE FACE HEREOF. PENTAIR HYDROMATIC SPECIFICALLY DISCLAIMS THE IMPLIED WARRANTIES OF MERCHANTABILITY AND FITNESS FOR ANY PARTICULAR PURPOSE.

**Liability Limitation:** IN NO EVENT SHALL PENTAIR HYDROMATIC BE LIABLE OR RESPONSIBLE FOR CONSEQUENTIAL, INCIDENTAL OR SPECIAL DAMAGES RESULTING FROM OR RELATED IN ANY MANNER TO ANY PENTAIR HYDROMATIC PRODUCT OR PARTS THEREOF. PERSONAL INJURY AND/OR PROPERTY DAMAGE MAY RESULT FROM IMPROPER INSTALLATION. PENTAIR HYDROMATIC DISCLAIMS ALL LIABILITY, INCLUDING LIABILITY UNDER THIS WARRANTY, FOR IMPROPER INSTALLATION. PENTAIR HYDROMATIC RECOMMENDS INSTALLATION BY PROFESSIONALS.

Some states do not permit some or all of the above warranty limitations or the exclusion or limitation of incidental or consequential damages and therefore such limitations may not apply to you. No warranties or representations at any time made by any representatives of Pentair Hydromatic shall vary or expand the provision hereof.



### HYDROMATIC®

740 EAST 9TH STREET  
ASHLAND, OHIO, USA 44805  
419-289-1144

490 PINEBUSH ROAD, UNIT #4  
CAMBRIDGE, ONTARIO, CANADA N1T 0A5  
800-363-PUMP

[WWW.HYDROMATIC.COM](http://WWW.HYDROMATIC.COM)